

Block 6: Argumentation in practice

Motivation: fraud intake

- **Online trade fraud** (10.000s complaints/year)
- Intake agent for **handling complaints**
- **Topic of inquiry:** should the complainant submit a complaint of trade fraud?

The screenshot shows the Dutch Police website's online complaint form for internet fraud. The page is titled "Aangifte internetoplichting" (Report internet fraud). It includes a navigation menu with options like "Home", "Aangifte of melding doen", "Mijn buurt", "Nieuws", "Gezocht & Vermist", "Thema's", and "Over de p...". The form is divided into sections: "Advertentie gegevens" (Advertisement details) and "Transactiegegevens" (Transaction details). The "Advertentie gegevens" section includes fields for "Waar bent u opgelicht?" (Where were you deceived?), "Advertentietitel" (Advertisement title), "Advertentienummer" (Advertisement number), "Uw accountnaam" (Your account name), "Accountnaam wederpartij" (Counterparty account name), and "Wat is er gebeurd?" (What happened?). The "Transactiegegevens" section includes fields for "Uw bankrekeningnummer" (Your bank account number), "Datum betaling" (Payment date), "Tijdstip betaling" (Payment time), and "Bedrag aankoop €" (Purchase amount in euros). A yellow box with the text "What happened?" is overlaid on the "Wat is er gebeurd?" field.

Bij spoed: 112
Geen spoed: 0900-8844

POLITIE

Home | Aangifte of melding doen | Mijn buurt | Nieuws | Gezocht & Vermist | Thema's | Over de p...

Home >

Aangifte internetoplichting

Vul onderstaande velden zo volledig mogelijk in. Wij wijzen u erop dat alles naar waarheid ingevuld moet worden.

De velden met een sterretje (*) moet u in elk geval invullen.

1. Aangever | 2. Wederpartij | **3. Conflict** | 4. Overzicht | ✓

Advertentie gegevens

Waar bent u opgelicht? *

Advertentietitel

Advertentienummer ?

Uw accountnaam * ?

Accountnaam wederpartij ?

Wat is er gebeurd? * ?

What happened?

Transactiegegevens

Uw bankrekeningnummer

Datum betaling * dd-mm-|||

Tijdstip betaling uu:mm

Bedrag aankoop € *

Requirements

- Handle natural language
- Give an accurate advice
- Explain the advice
- Handle incomplete information
- React fast



User inserts natural language text
(in Dutch)

<https://aangifte.politie.nl/iaai-preintake/#/>



User inserts natural language text
(in Dutch)

<https://aangifte.politie.nl/iaai-preintake/#/>

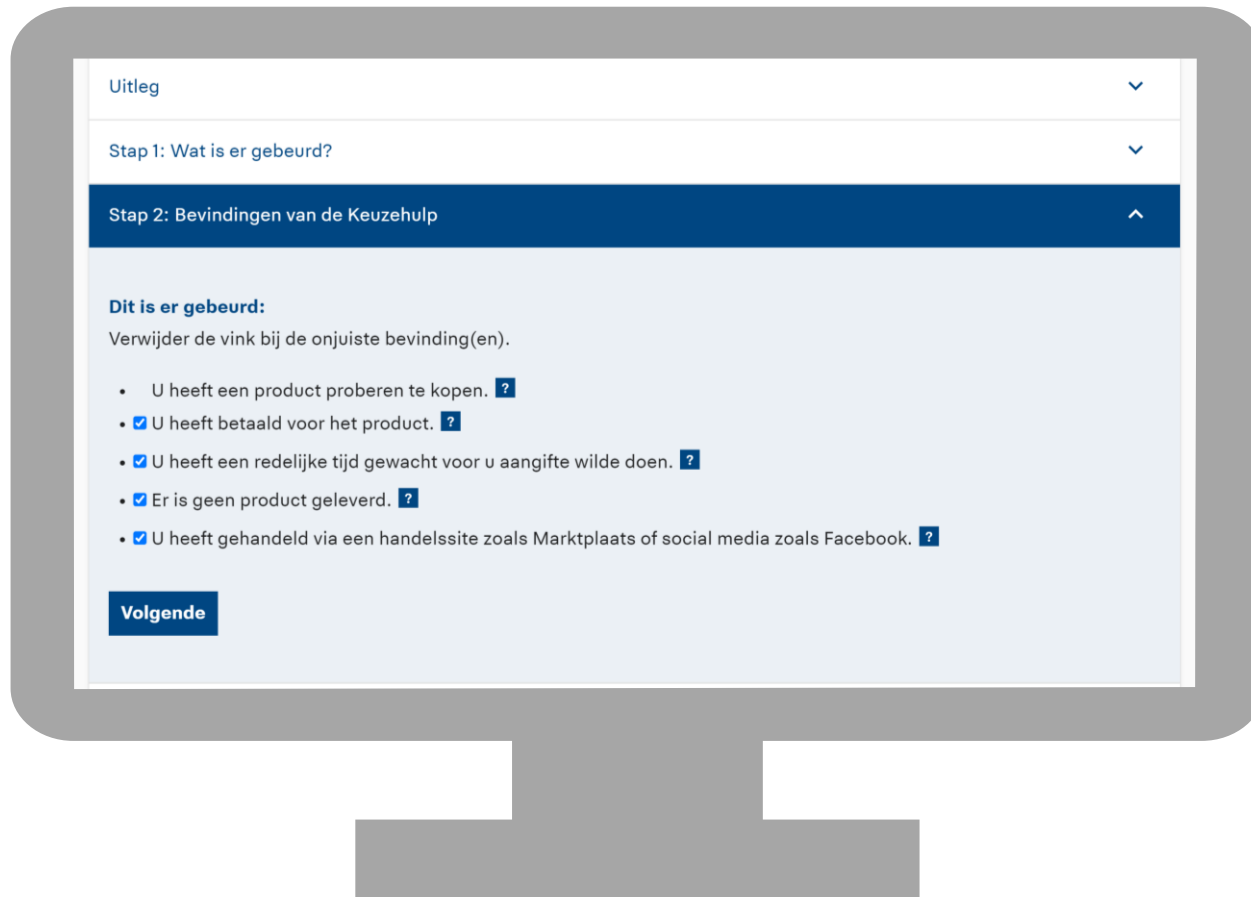

Information Extraction module
extracts observations

<https://aangifte.politie.nl/iaai-preintake/#/>

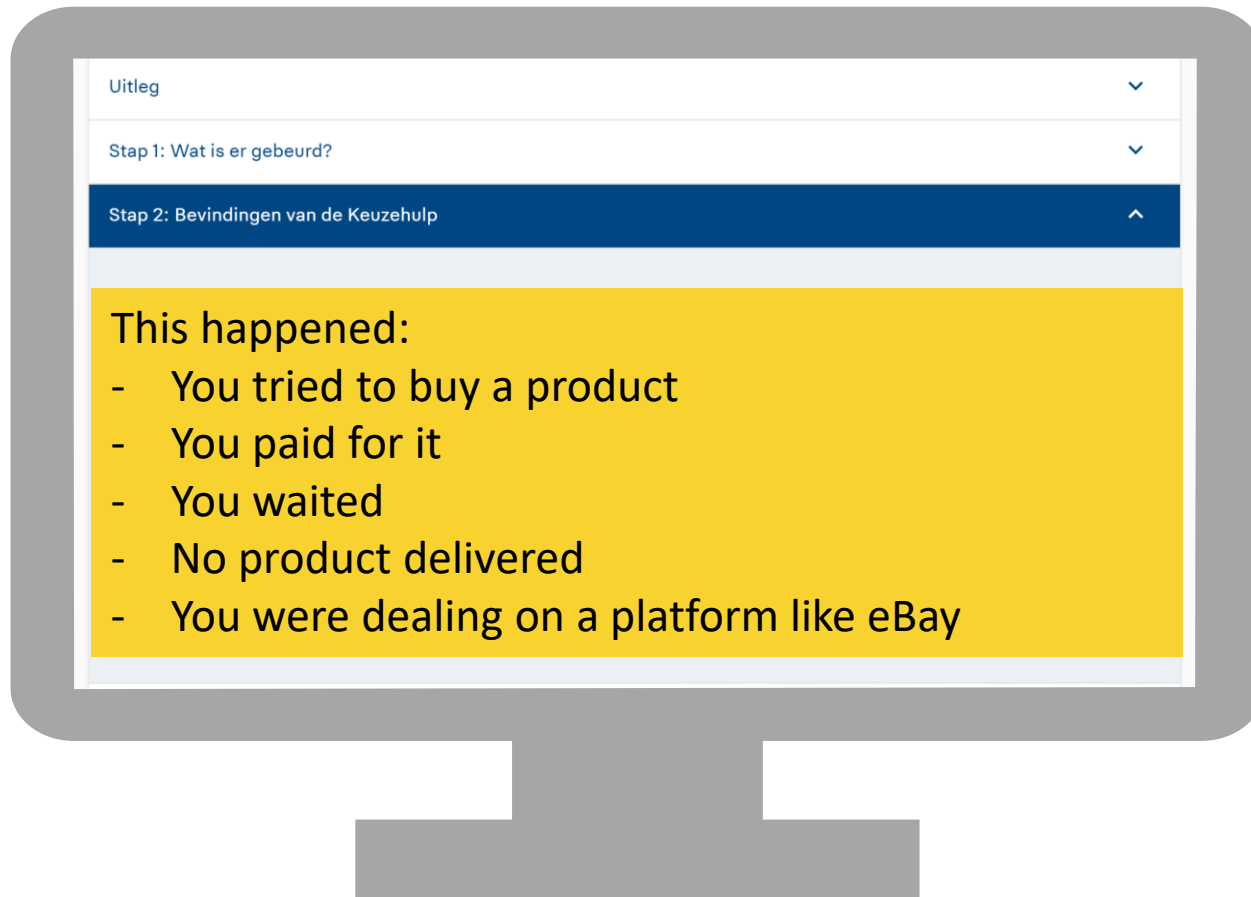

<https://aangifte.politie.nl/iaai-preintake/#/>

Information Extraction module
extracts observations

Stap 1: Wat is er gebeurd? ▾

Stap 2: Bevindingen van de Keuzehulp ▾

Stap 3: Vragen over wat er is gebeurd ▲

Naar aanleiding van uw verhaal heeft de Keuzehulp nog enkele vragen.

Zou u een product per post toegestuurd krijgen? Ja Nee

Eventuele extra toelichting: 0 / 200

Heeft u een Track en Trace code van de verkoper ontvangen voordat u betaald heeft? Ja Nee

Eventuele extra toelichting: 0 / 200

Volgende

Information was not sufficient:
user needs to answer additional
questions

<https://aangifte.politie.nl/iaai-preintake/#/>

Stap 1: Wat is er gebeurd? ▾

Stap 2: Bevindingen van de Keuzehulp ▾

Stap 3: Vragen over wat er is gebeurd ▲

Naar aanleiding van uw verhaal heeft de Keuzehulp nog enkele vragen.

Were you expecting a postal package?

Eventuele extra toelichting: 0 / 200

Did you get a track&trace code?

Eventuele extra toelichting: 0 / 200

Volgende

Information was not sufficient:
user needs to answer additional
questions

<https://aangifte.politie.nl/iaai-preintake/#/>

Stap 4: Ons advies

Ons advies: Aangifte doen ?

Op basis van uw verhaal raadt de Keuzehulp u aan om door te gaan met uw aangifte.

Klik hieronder op 'Doorgaan met aangifte'. U krijgt dan een formulier te zien waarin u verdere details, zoals adressen en betaalgegevens, kunt invullen.

Let op: uw aangifte is pas afgerond nadat u het volgende aangifteformulier heeft ingevuld en verzonden.

Wat u verder nog kunt doen ?

Naast het doen van aangifte (als dat van toepassing is) kunt u zelf proberen een oplossing te vinden met de verkoper.

- Mogelijk kan het [Juridisch loket](#) of de [Rechtstelefoon](#) u hierbij helpen.
- Op [consuwijzer.nl](#) vindt u praktische informatie over uw rechten.
- Op de [pagina "internetplichting" van de politie](#) vindt u meer informatie over internetplichting.
- Op de [pagina "internetplichting" van de politie](#) vindt u informatie over uw mogelijkheden als u een rechtsbijstandverzekering heeft.

Ons advies volgt uit wat er is gebeurd:

- U heeft een product proberen te kopen. ?
- U heeft betaald voor het product. ?
- U heeft een redelijke tijd gewacht voor u aangifte wilde doen. ?
- Er is geen product geleverd. ?

Advice

<https://aangifte.politie.nl/iaai-preintake/#/>

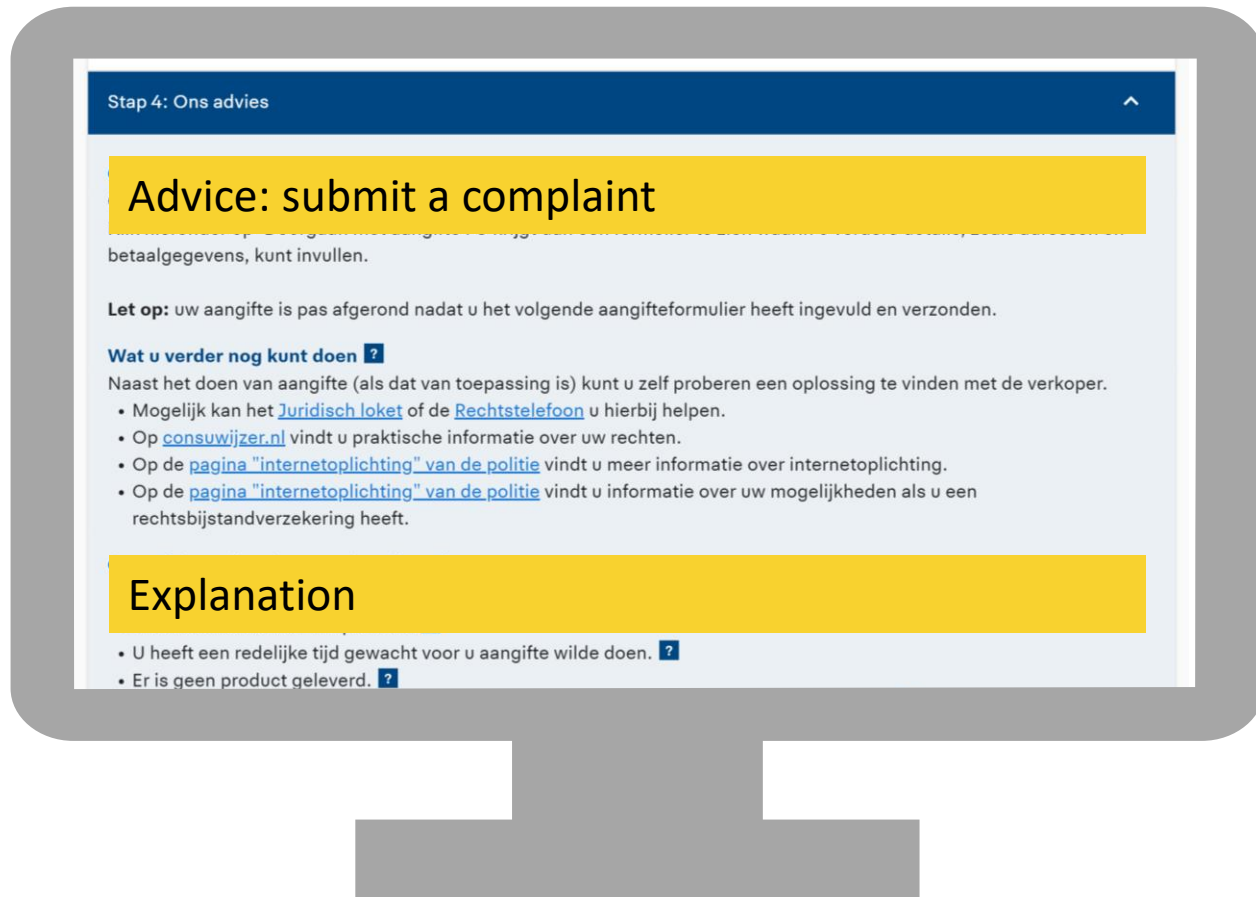

Advice

<https://aangifte.politie.nl/iaai-preintake/#/>

POLITIE





8-1334yfl 6400 kg
AIRSERVICE
VW AG

ACHTUNG! WARNUNG! ATTENTION!
WARNING! WARNING! ATTENTION!
The engine compartment contains many hot and moving parts. Do not touch these parts when the engine is running or immediately after the engine has stopped. The engine compartment contains many electrical components. Do not touch these components when the engine is running or immediately after the engine has stopped. Do not use flammable liquids in the engine compartment. Do not use open flames in the engine compartment. Do not use the engine compartment as a storage area for tools, rags, or other debris.

Remise/service
Remise/service
Remise/service

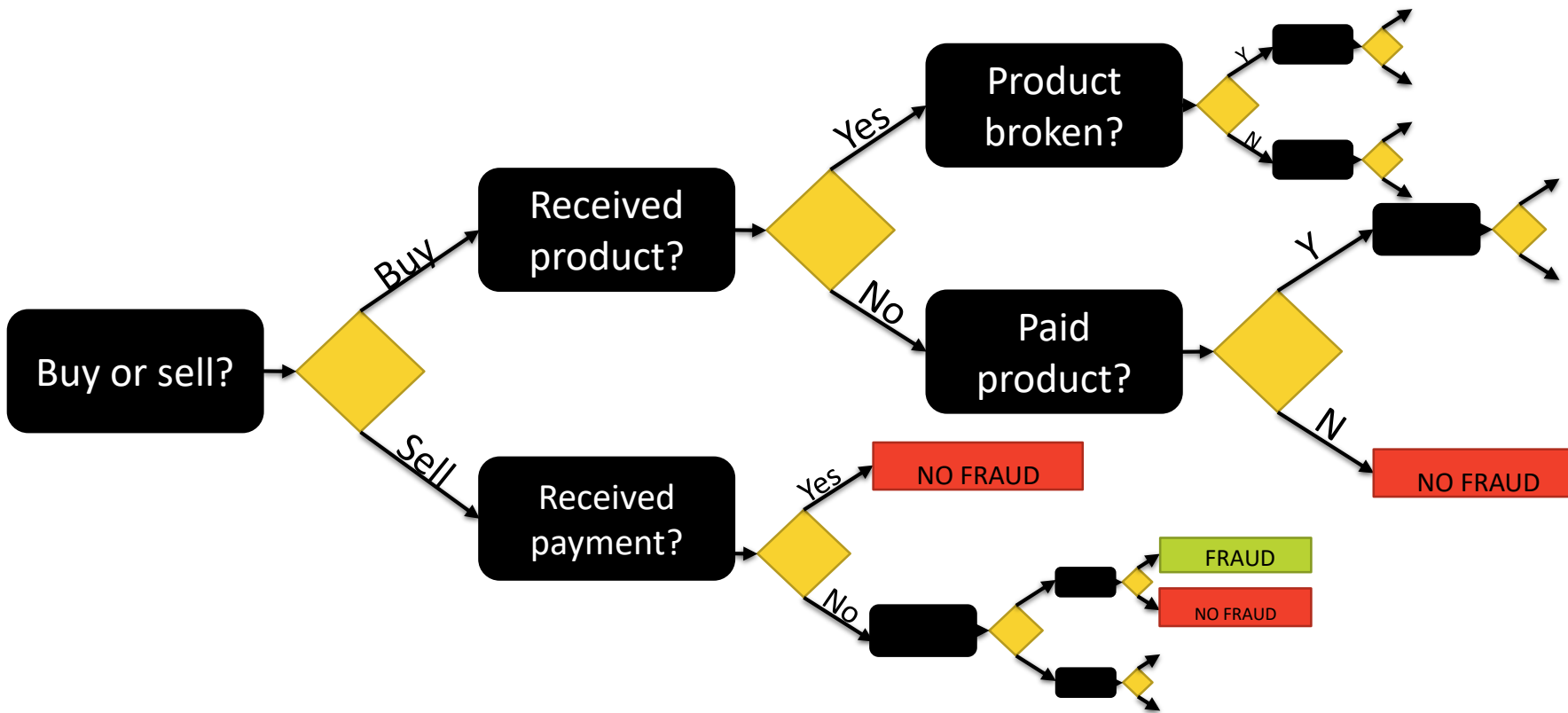

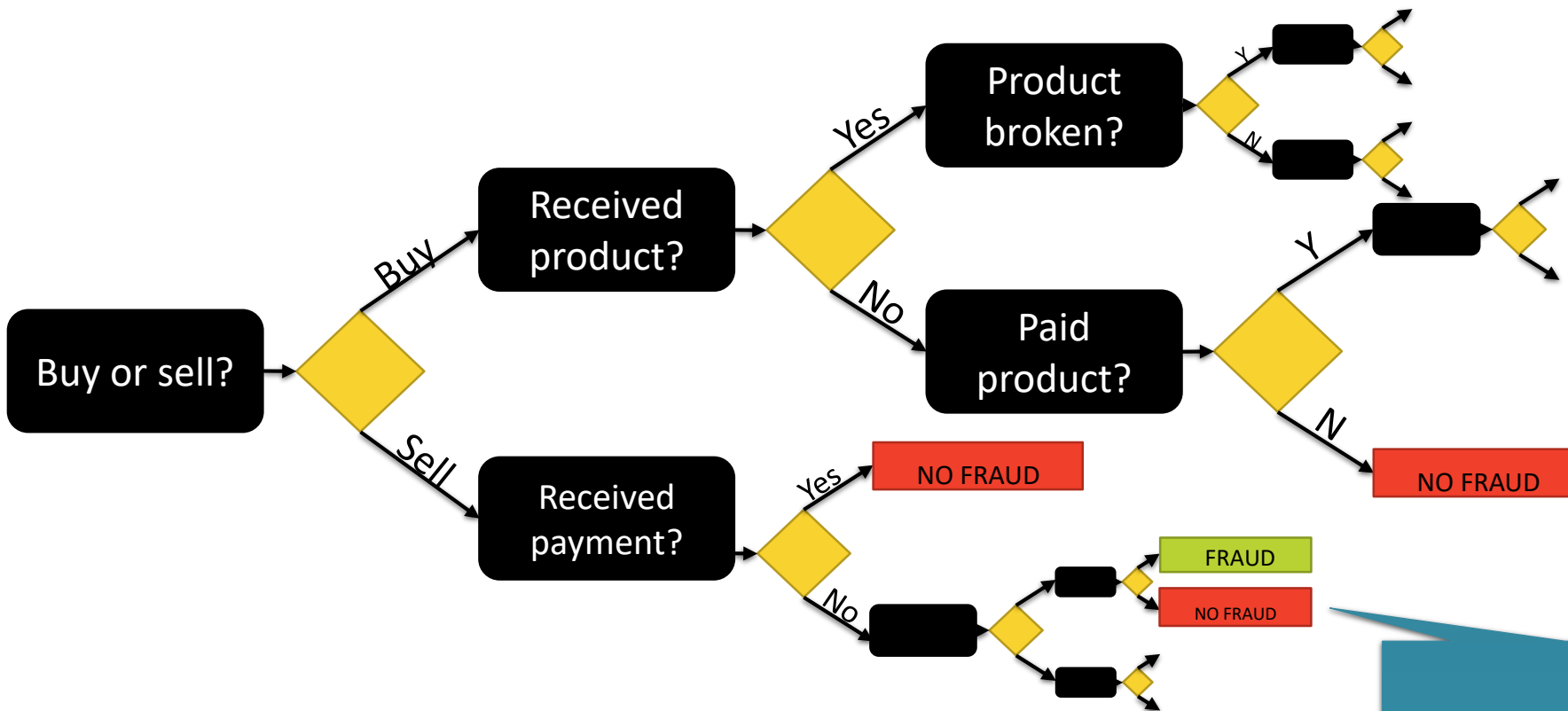

But why?

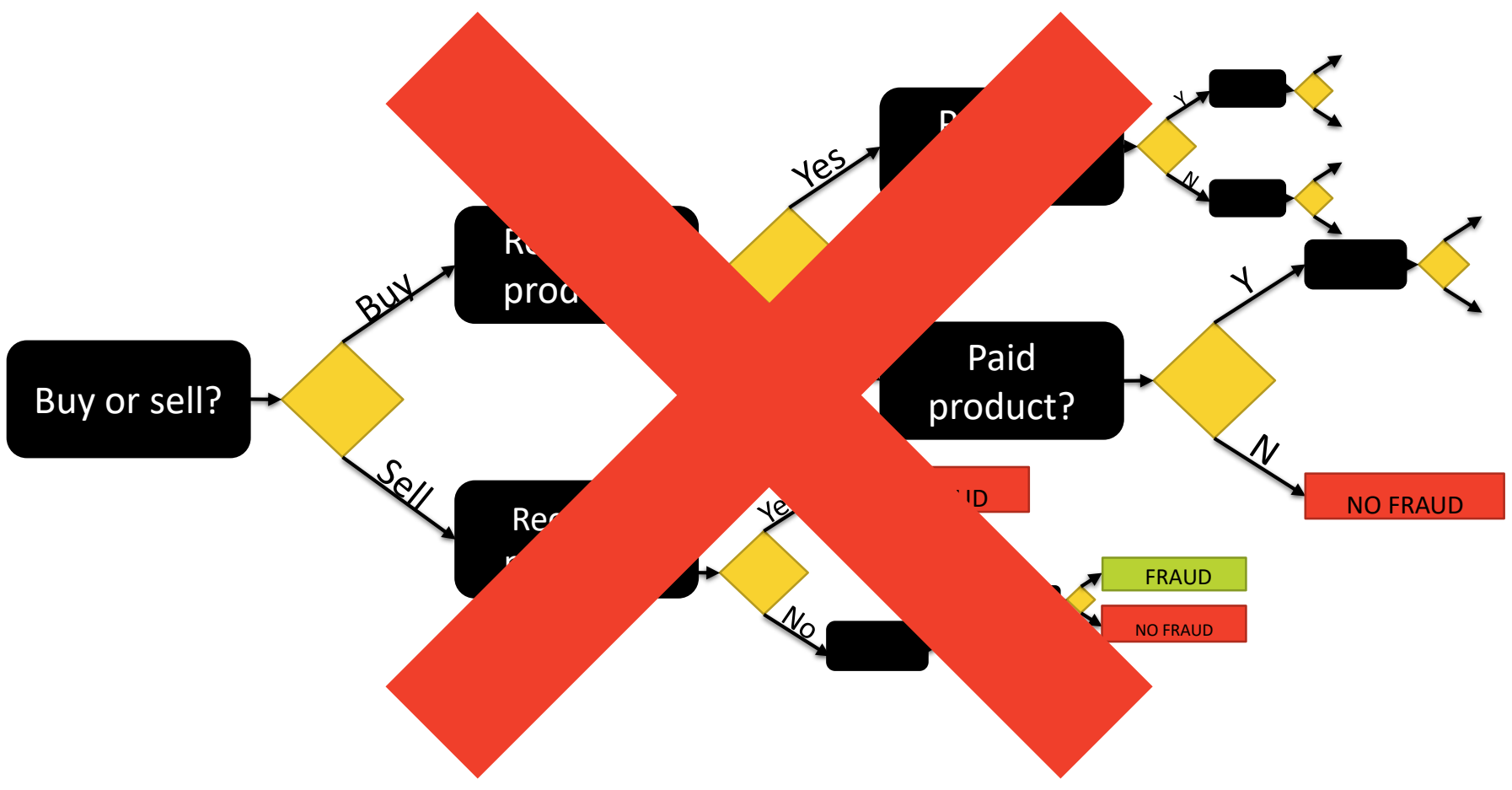

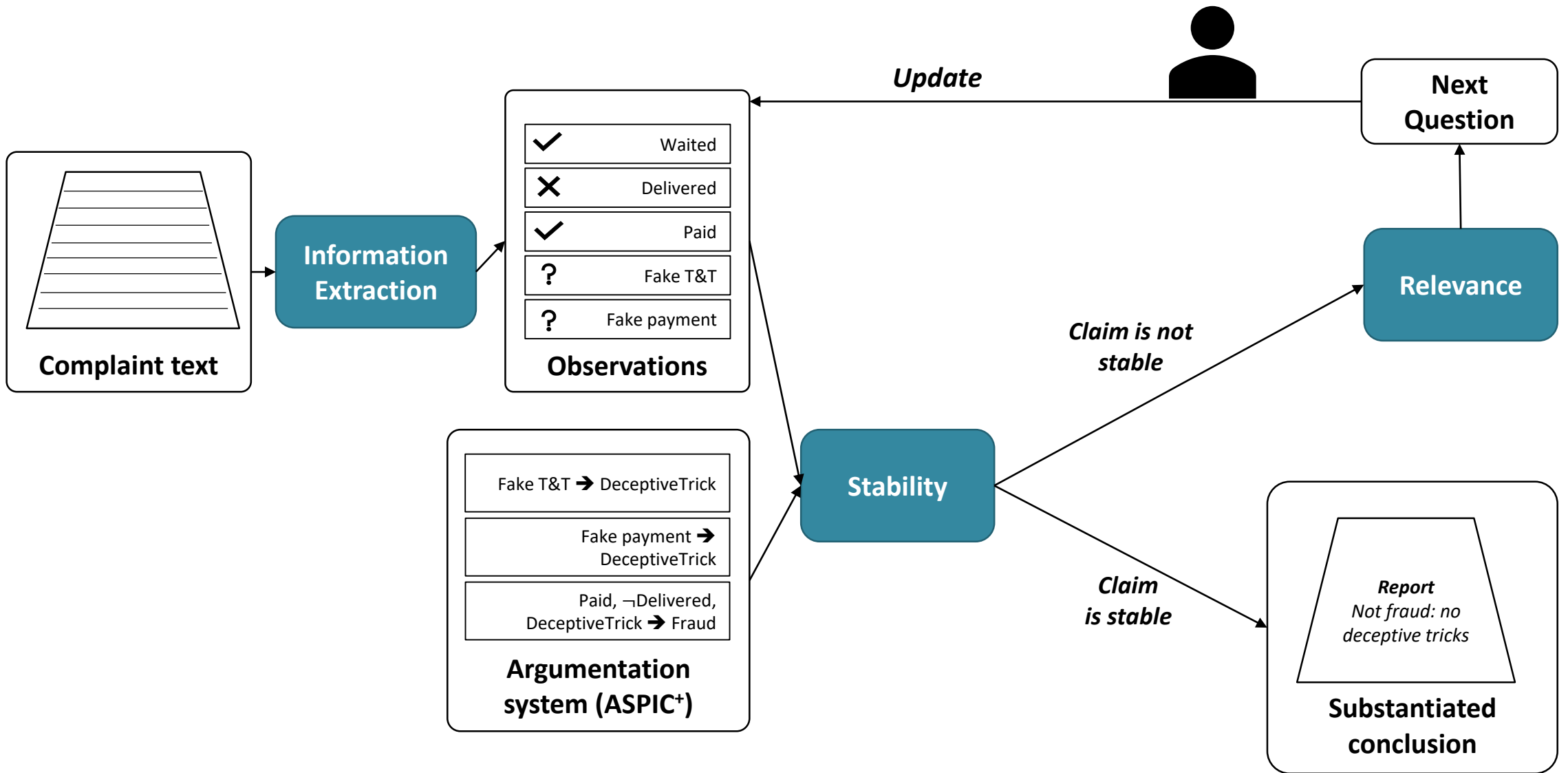

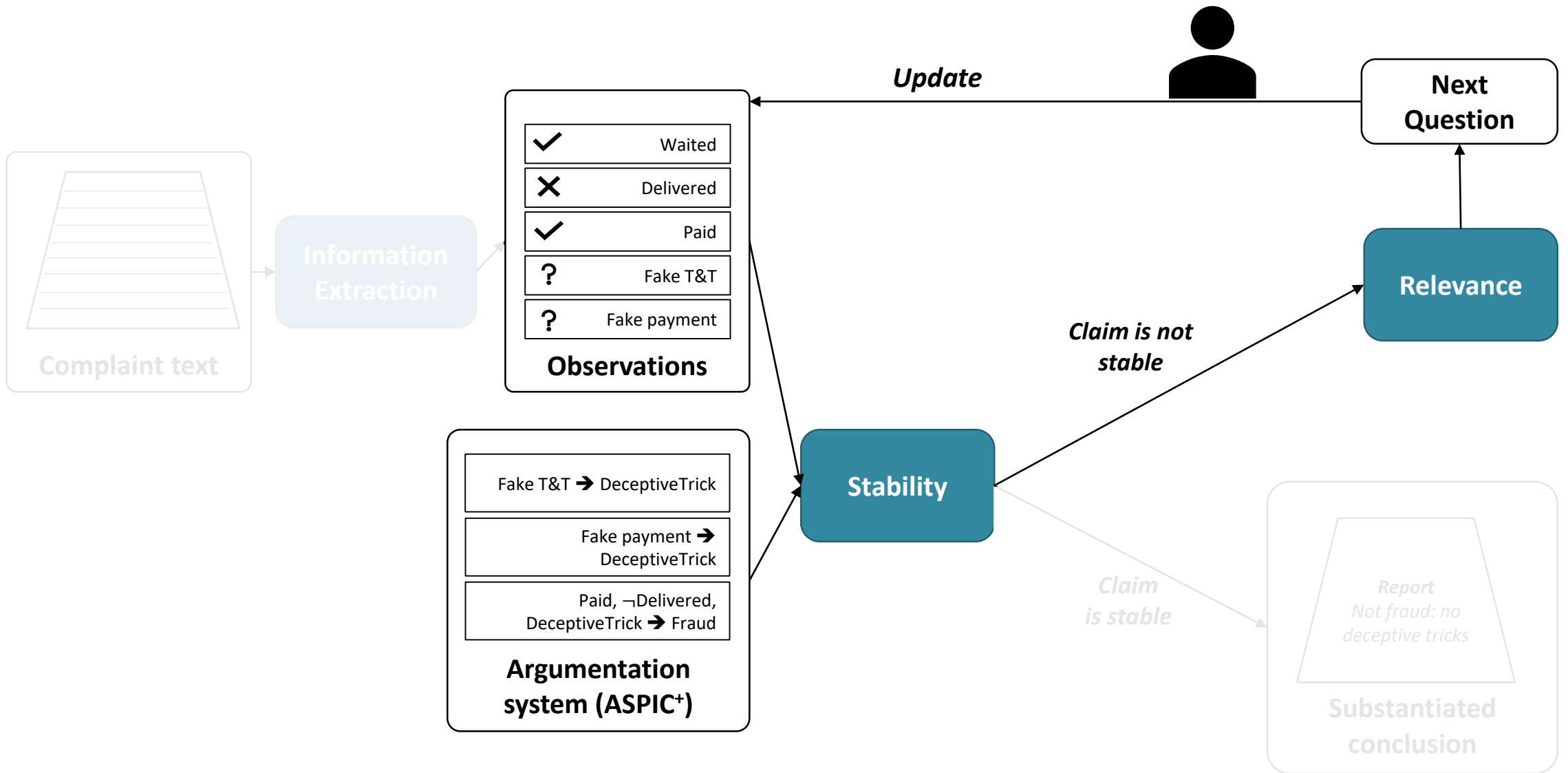

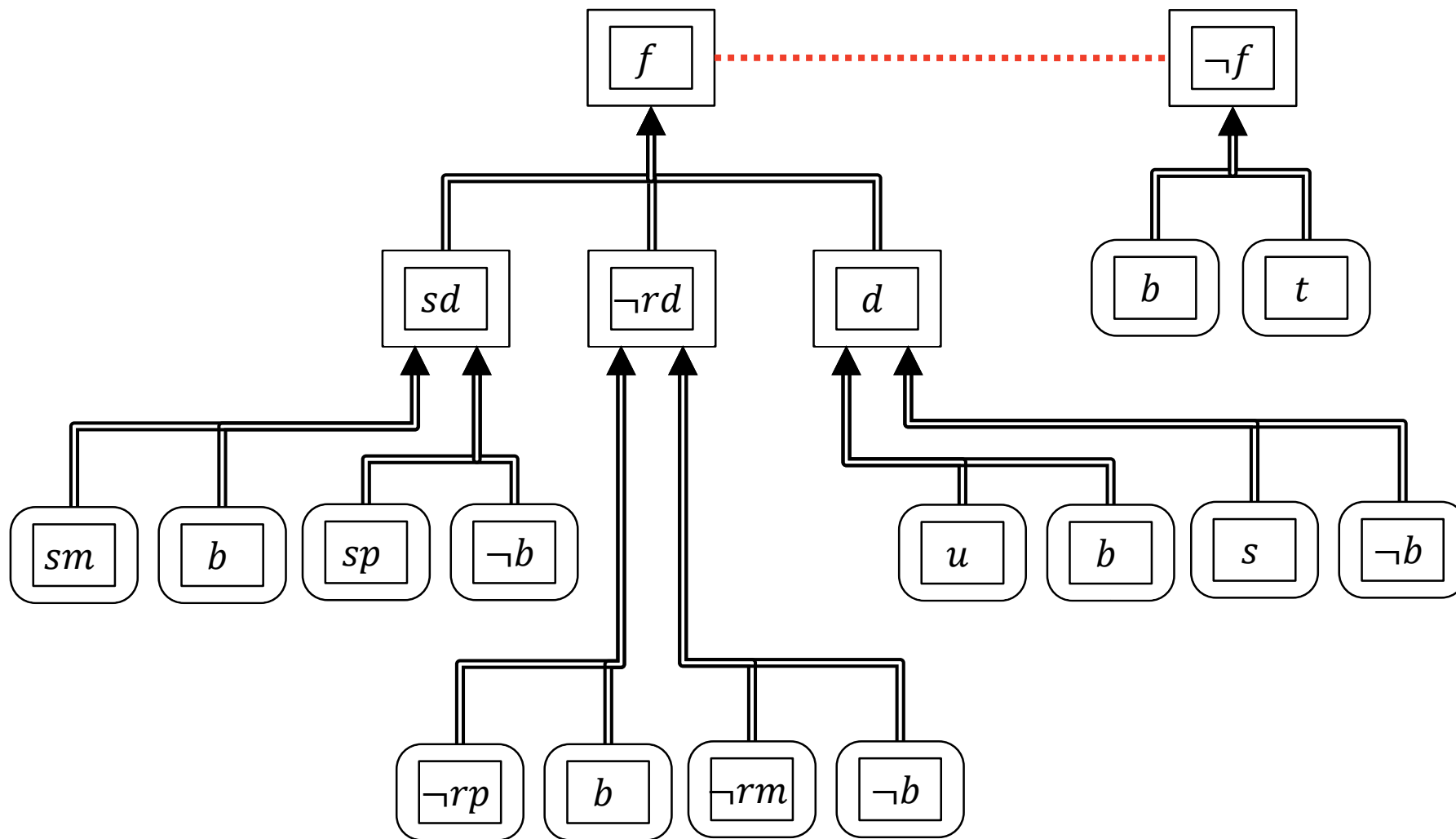

f: fraud
sd: sent delivery
rd: received delivery
d: deception
b: citizen tried to buy
t: trusted web shop
sp: sent product
rp: received product
sm: sent money
rm: received money
u: suspicious url
s: screenshot payment

Citizens who sent a delivery but did not receive a delivery and were deceived, usually are victim of fraud.

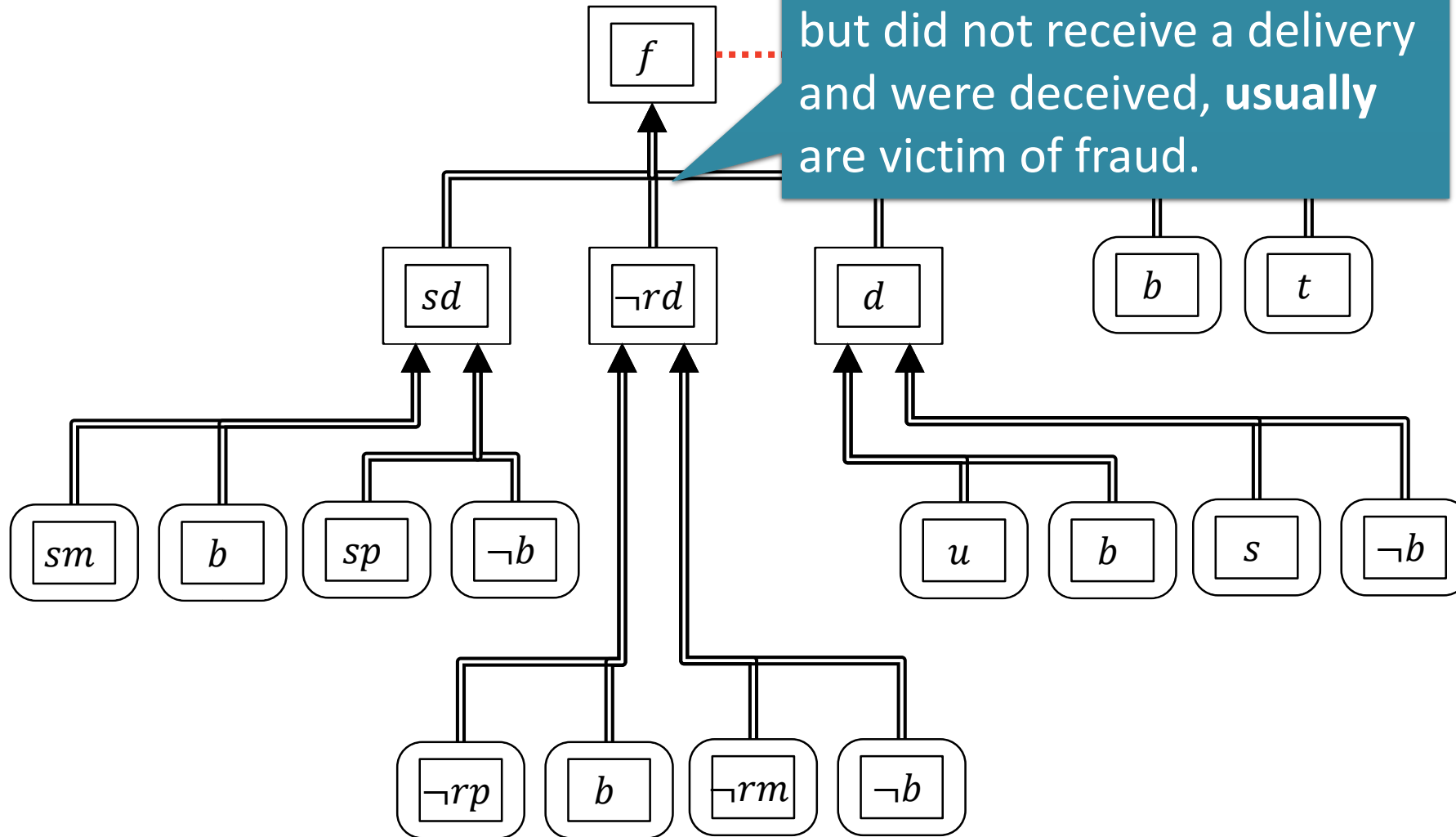

- f*: fraud
- sd*: sent delivery
- rd*: received delivery
- d*: deception
- b*: citizen tried to buy
- t*: trusted web shop
- sp*: sent product
- rp*: received product
- sm*: sent money
- rm*: received money
- u*: suspicious url
- s*: screenshot payment

Citizens who bought products on a web shop trusted by the police **usually** are not a victim of fraud.

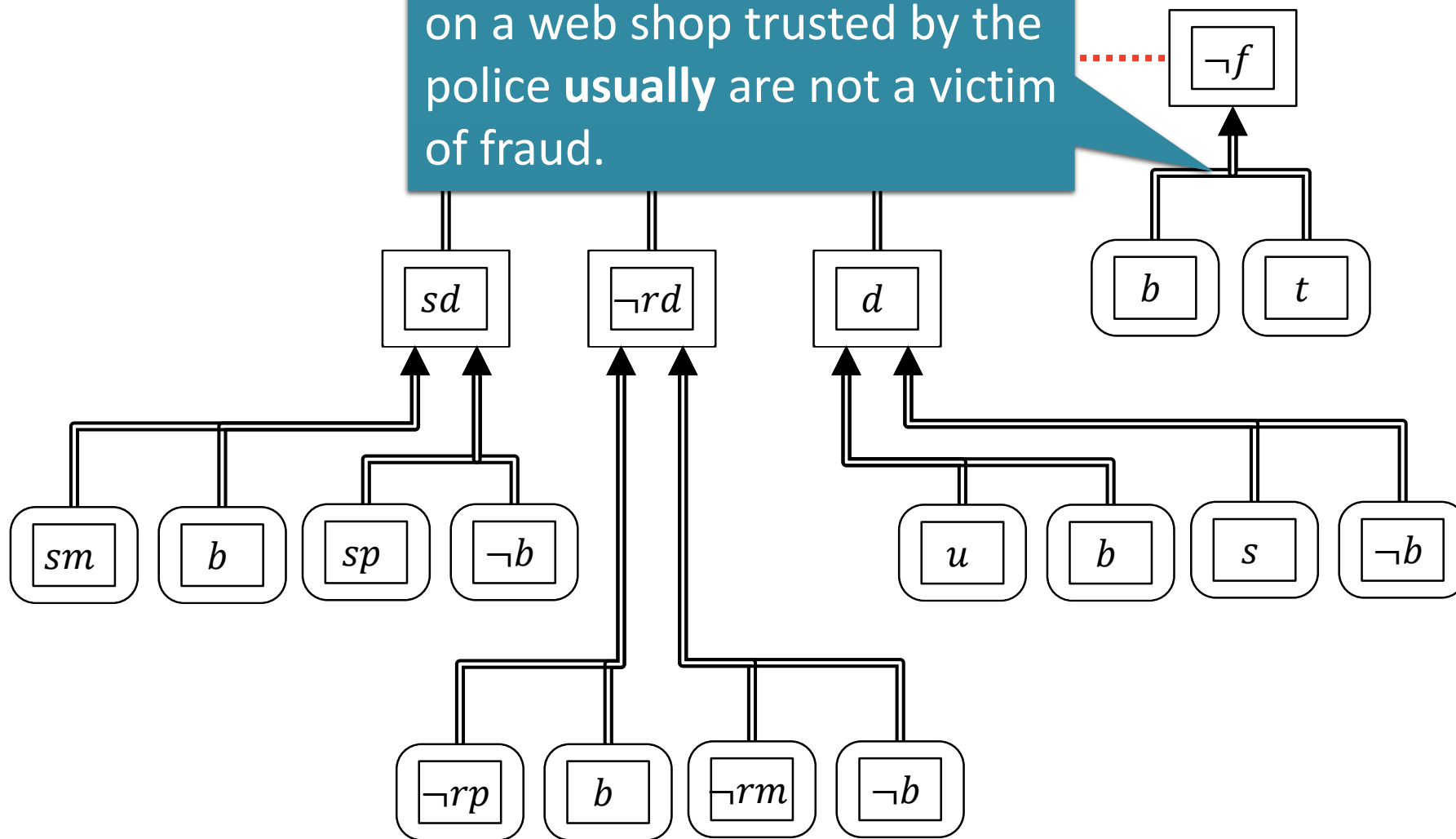

f: fraud
sd: sent delivery
rd: received delivery
d: deception
b: citizen tried to buy
t: trusted web shop
sp: sent product
rp: received product
sm: sent money
rm: received money
u: suspicious url
s: screenshot payment

Q

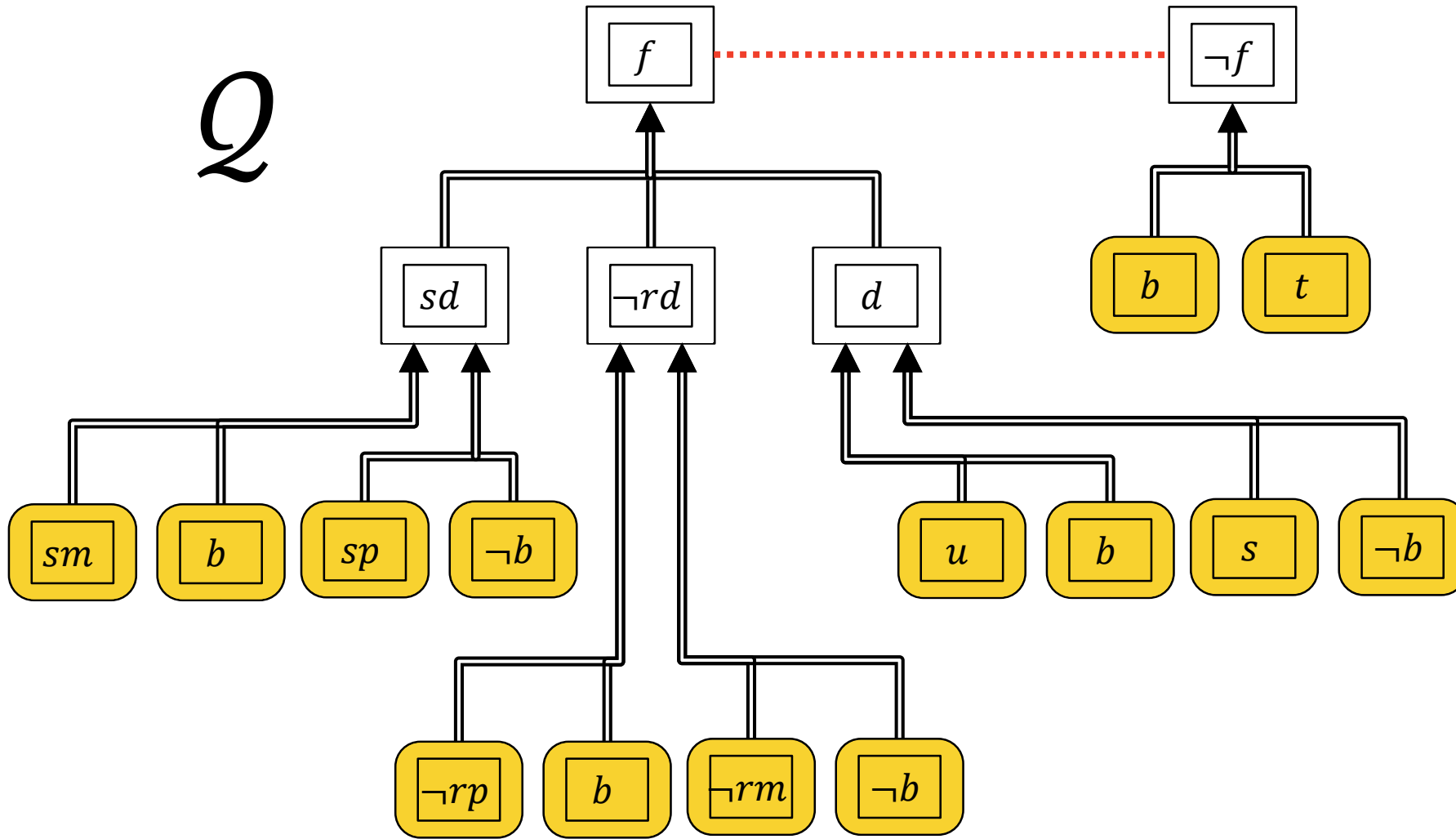

f: fraud
sd: sent delivery
rd: received delivery
d: deception
b: citizen tried to buy
t: trusted web shop
sp: sent product
rp: received product
sm: sent money
rm: received money
u: suspicious url
s: screenshot payment

There is a **rule-based argument** for "fraud"

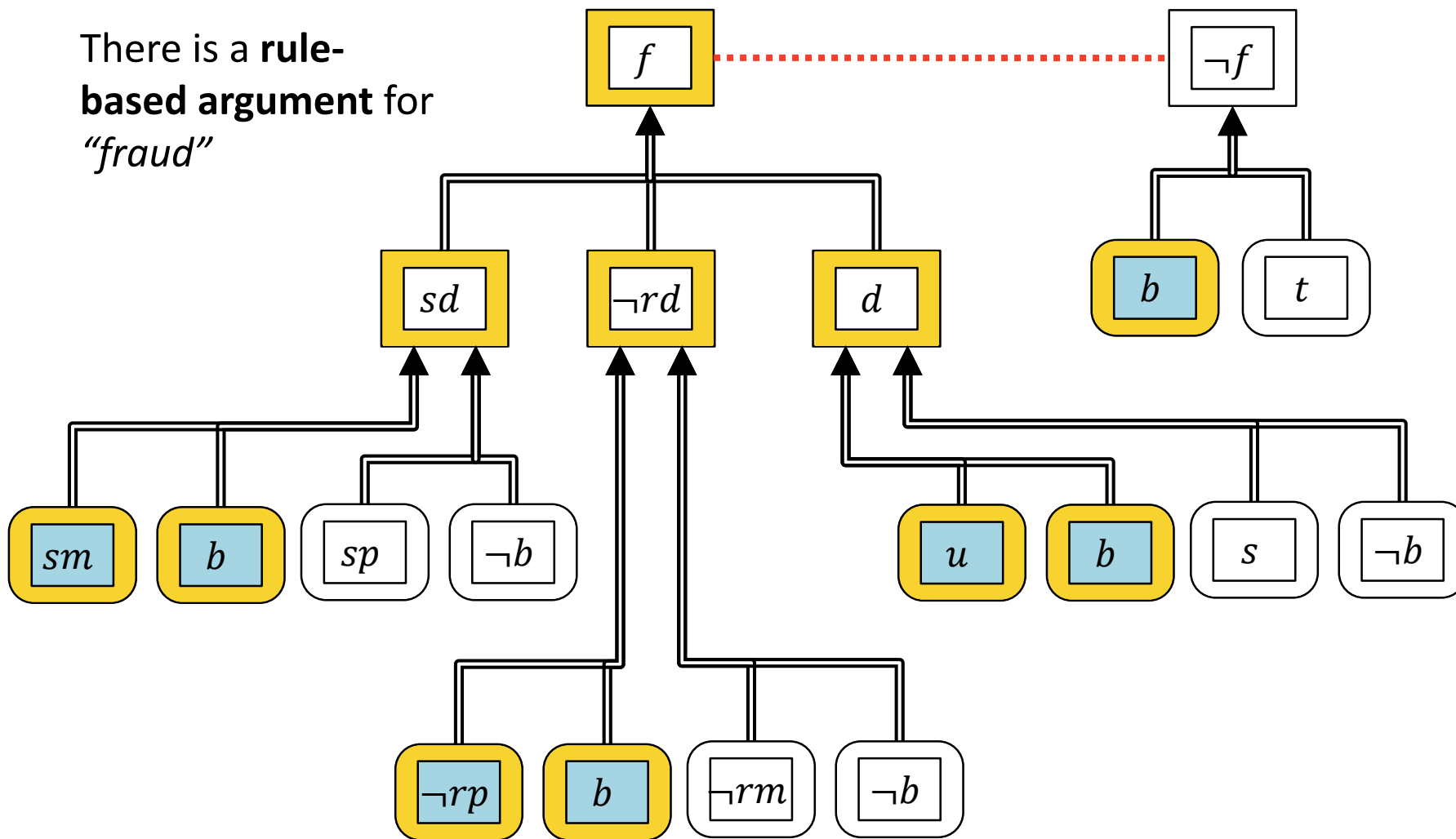

f: fraud
sd: sent delivery
rd: received delivery
d: deception
b: citizen tried to buy
t: trusted web shop
sp: sent product
rp: received product
sm: sent money
rm: received money
u: suspicious url
s: screenshot payment

Claim acceptability statuses

Unsatisfiable	There is no argument for l in $Arg(AT)$
Defended	There exists an argument for l in $Arg(AT)$ that is also in the grounded extension $G(AT)$
Out	There exists an argument for l in $Arg(AT)$ but each argument for l in $Arg(AT)$ is attacked by an argument in the grounded extension $G(AT)$
Blocked	There exists an argument for l in $Arg(AT)$, but no argument for l is in the grounded extension $G(AT)$ and at least one argument for l is not attacked by an argument in $G(AT)$

Claim acceptability statuses

Unsatisfiable	No argument for claim
Defended	Winning argument for claim
Out	Only losing arguments for claim
Blocked	Arguments for/contra claim are equal

User: "I tried to buy a product, paid for it but did not receive anything and the url looks suspicious."

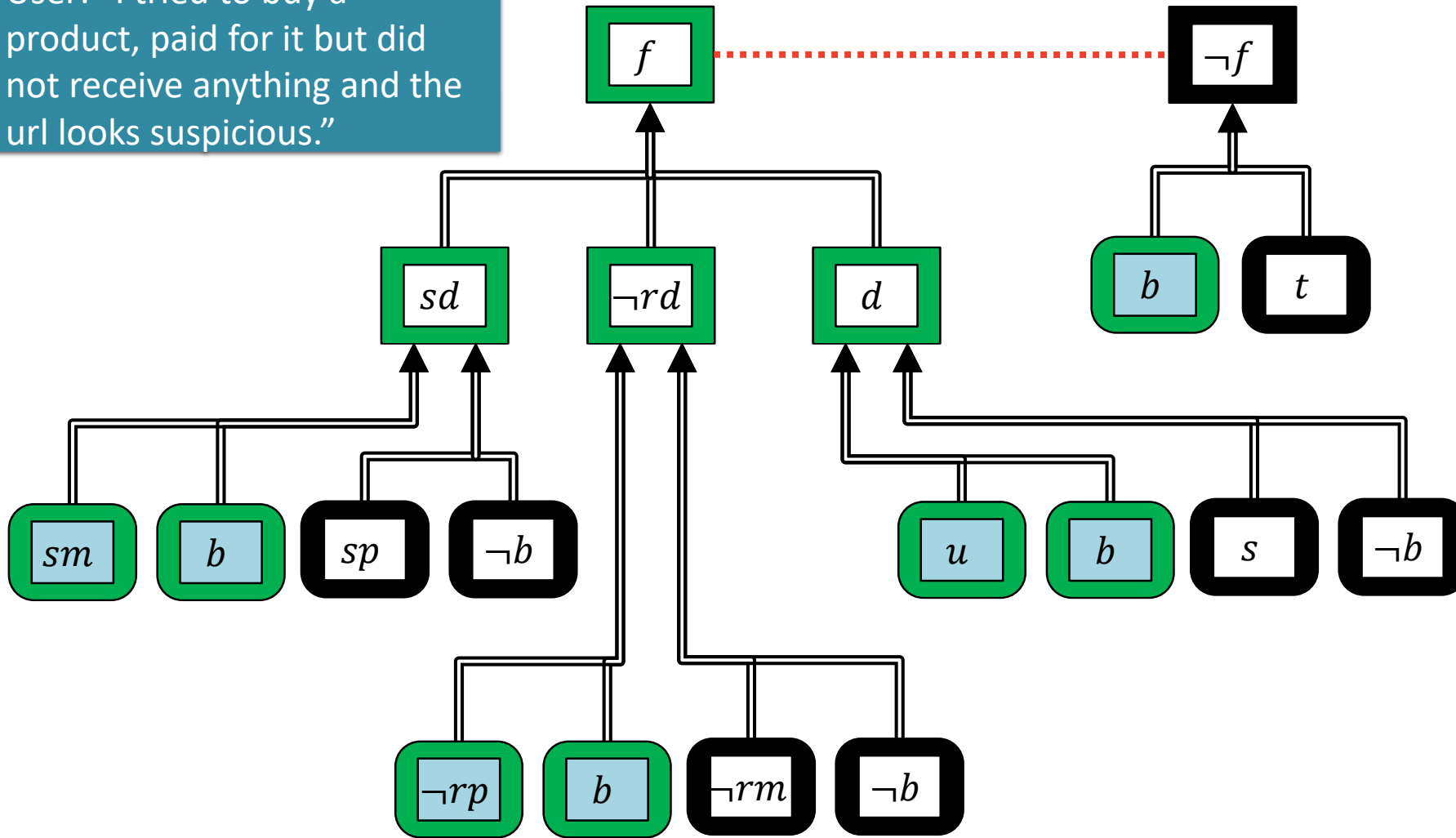

f: fraud
sd: sent delivery
rd: received delivery
d: deception
b: citizen tried to buy
t: trusted web shop
sp: sent product
rp: received product
sm: sent money
rm: received money
u: suspicious url
s: screenshot payment

User: "I tried to buy a product, paid for it but did not receive anything and the url looks suspicious."

Police API: "Url has been checked before and is trustworthy."

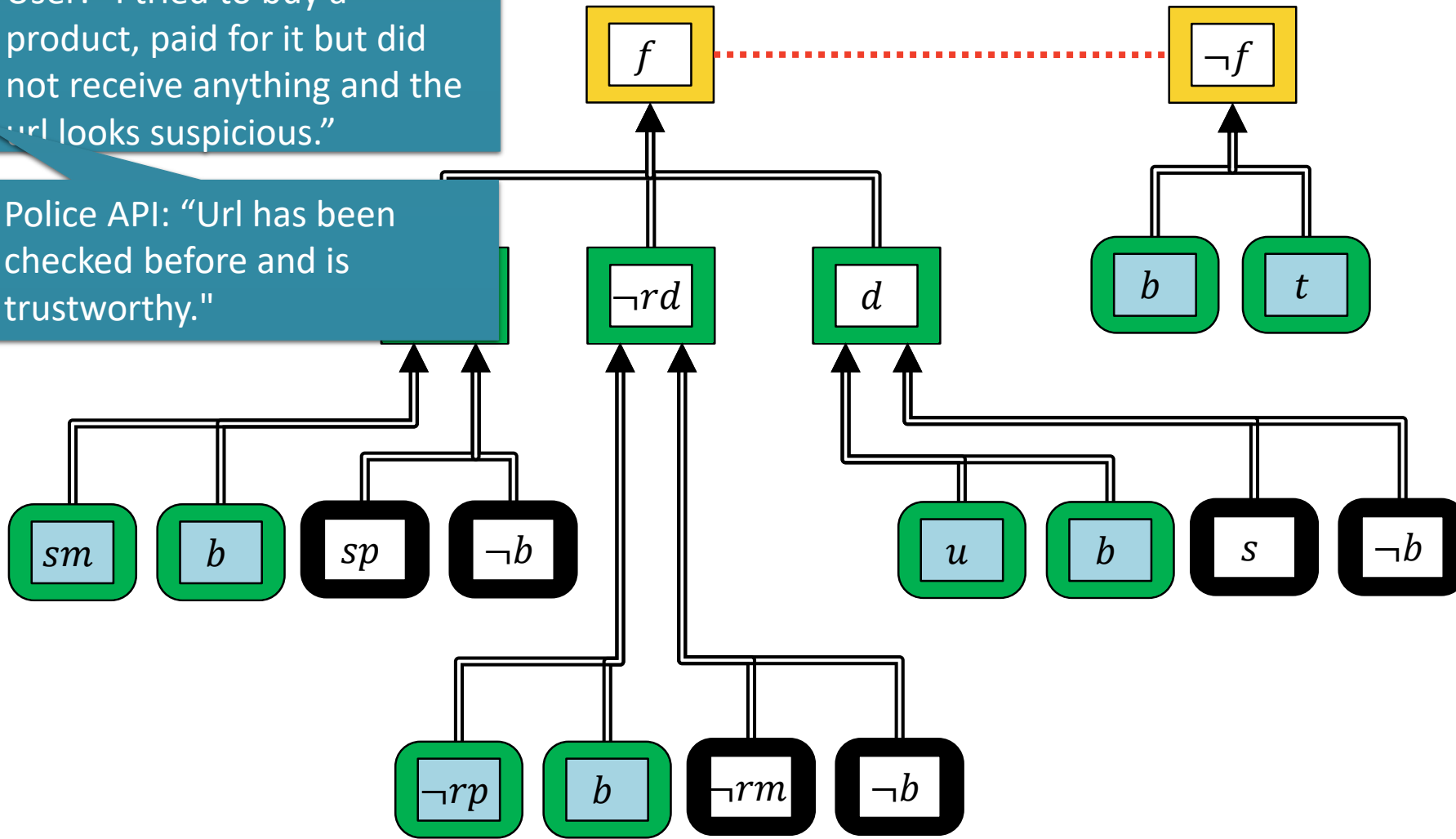

f : fraud
 sd : sent delivery
 rd : received delivery
 d : deception
 b : citizen tried to buy
 t : trusted web shop
 sp : sent product
 rp : received product
 sm : sent money
 rm : received money
 u : suspicious url
 s : screenshot payment

Stability

A claim is **stable** if the acceptability status remains the same in all ways in which uncertainty can be resolved.*

*For a formal definition see:

Odekerken, D., Bex, F., Borg, A., & Testerink, B. (2022). Approximating stability for applied argument-based inquiry. *Intelligent Systems with Applications*, 16, 200110.

User: "I don't know what to say..."

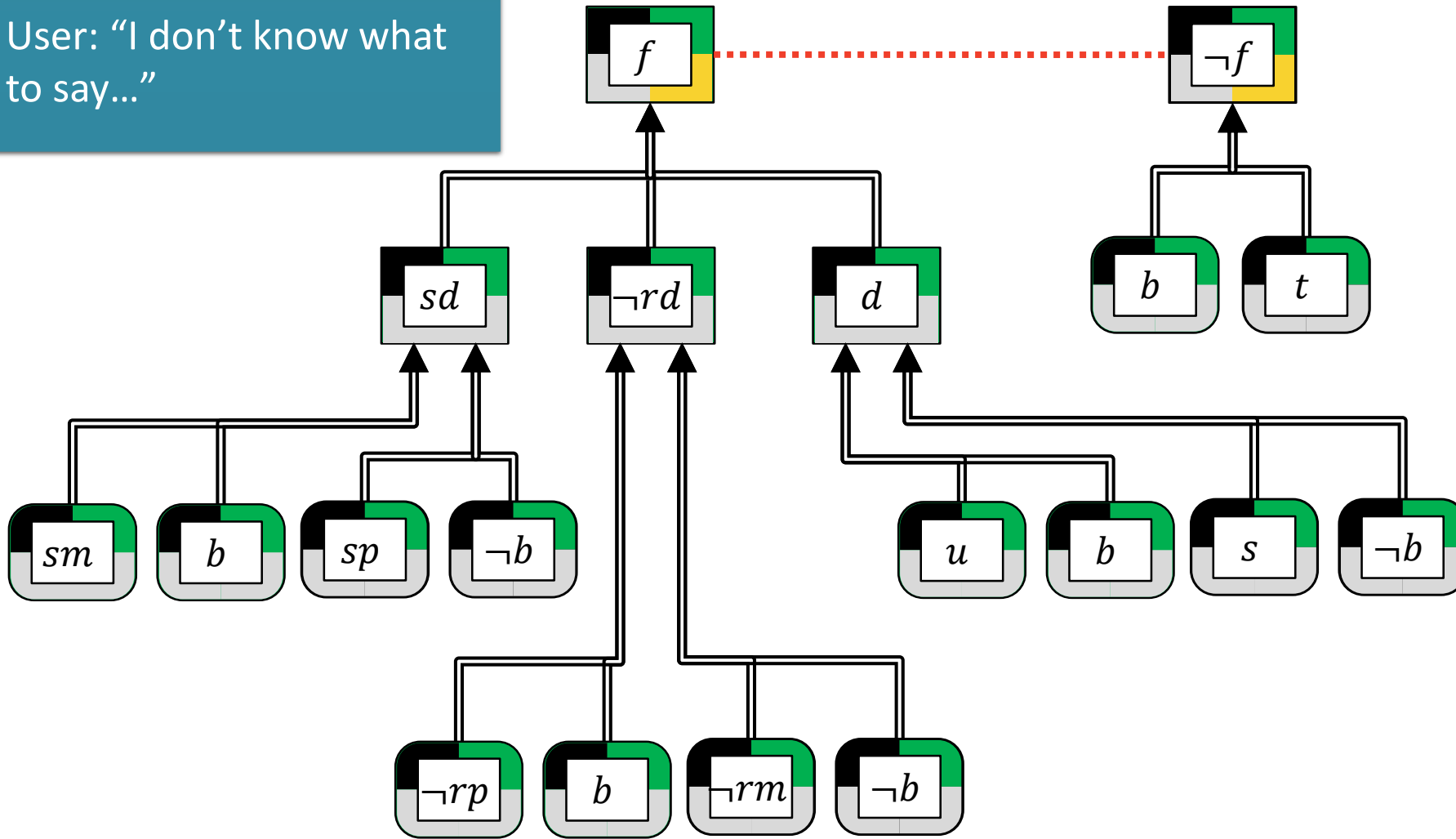

f: fraud
sd: sent delivery
rd: received delivery
d: deception
b: citizen tried to buy
t: trusted web shop
sp: sent product
rp: received product
sm: sent money
rm: received money
u: suspicious url
s: screenshot payment

User: "I tried to buy a product."

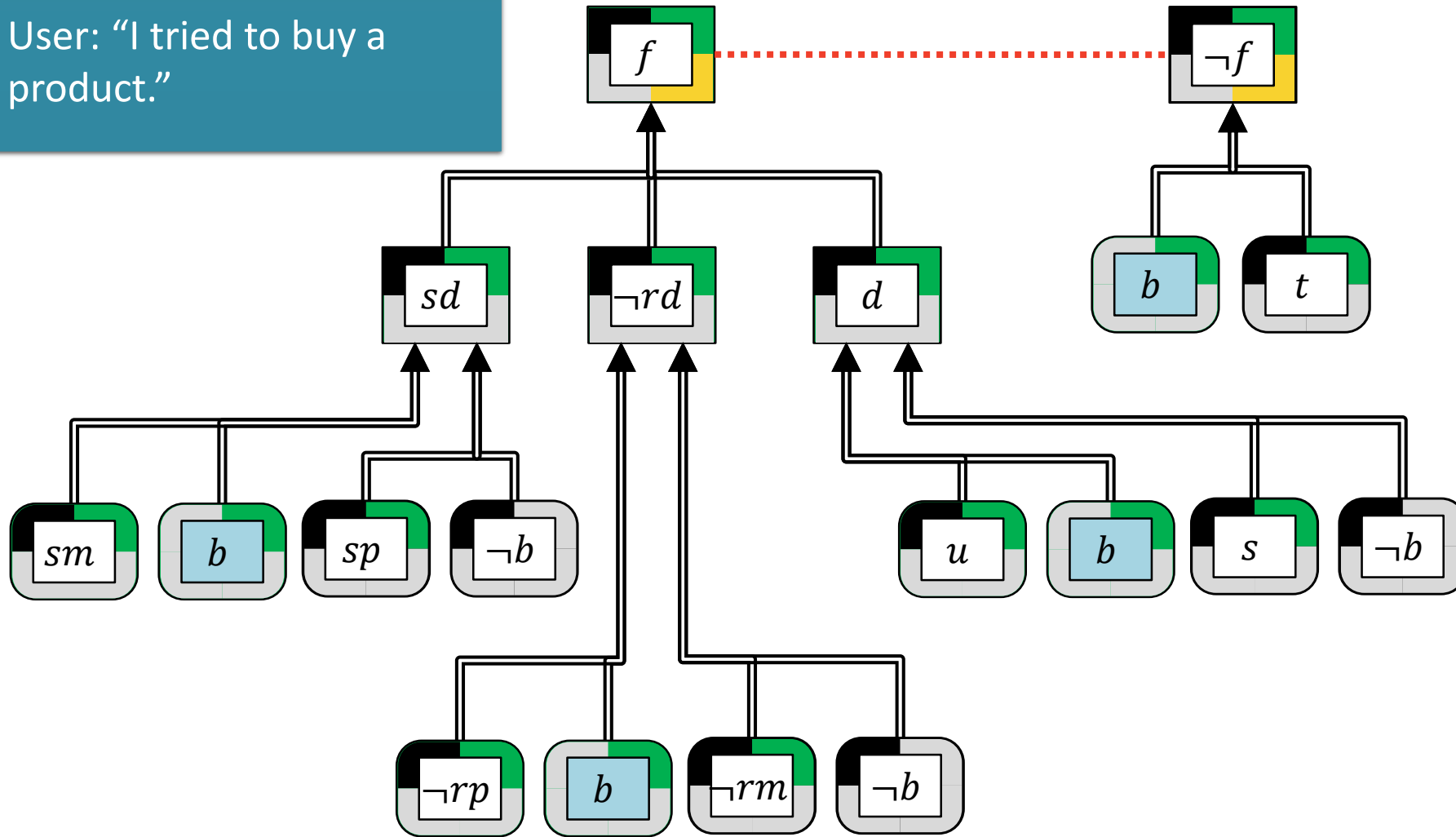

f: fraud
sd: sent delivery
rd: received delivery
d: deception
b: citizen tried to buy
t: trusted web shop
sp: sent product
rp: received product
sm: sent money
rm: received money
u: suspicious url
s: screenshot payment

User: "I tried to buy a product, paid for it but did not receive anything and the url looks suspicious."

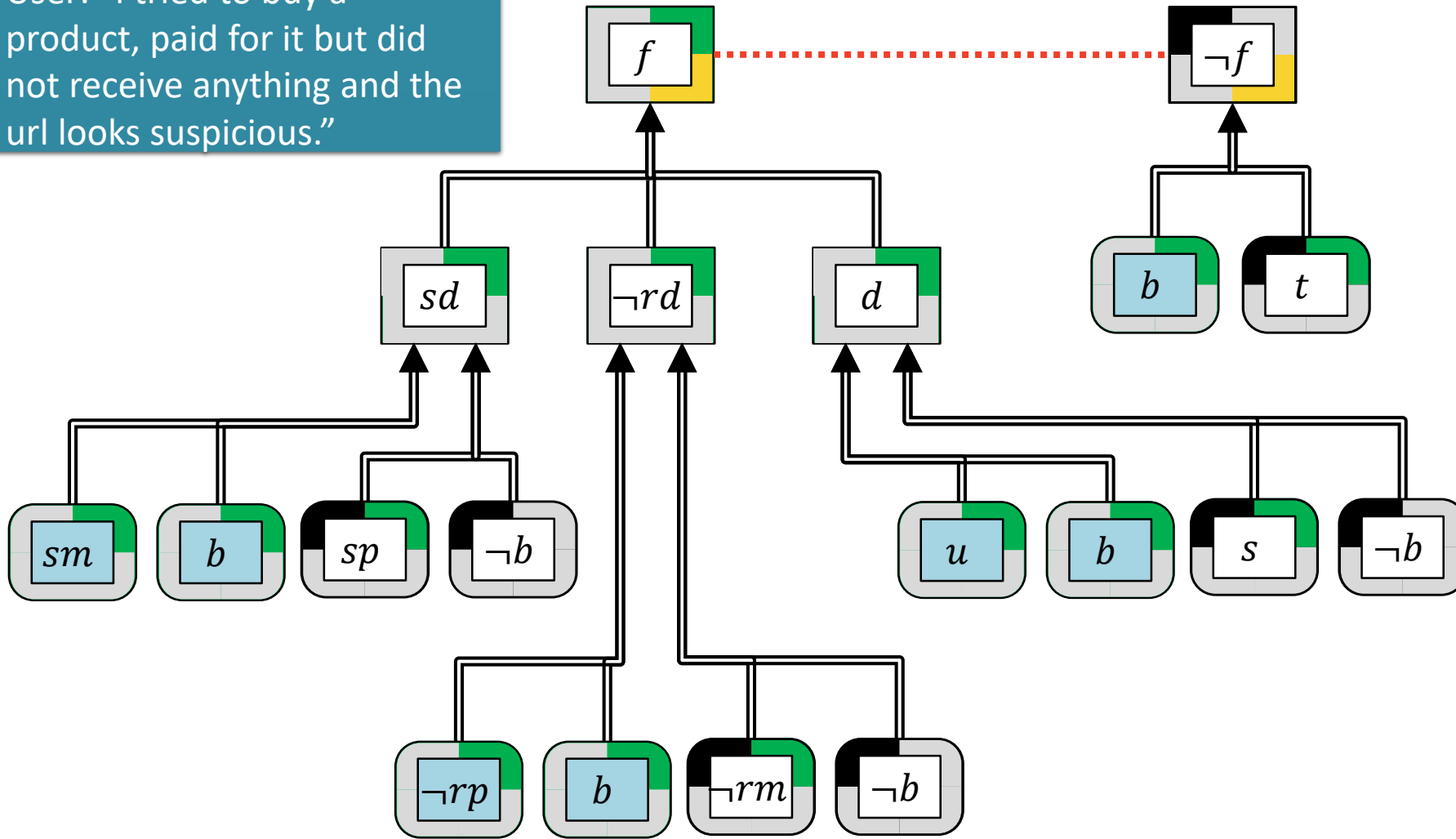

f: fraud
sd: sent delivery
rd: received delivery
d: deception
b: citizen tried to buy
t: trusted web shop
sp: sent product
rp: received product
sm: sent money
rm: received money
u: suspicious url
s: screenshot payment

User: "I tried to buy a product, paid for it but did not receive anything and the url looks suspicious."

Police API: "Url has been checked before and is trustworthy."

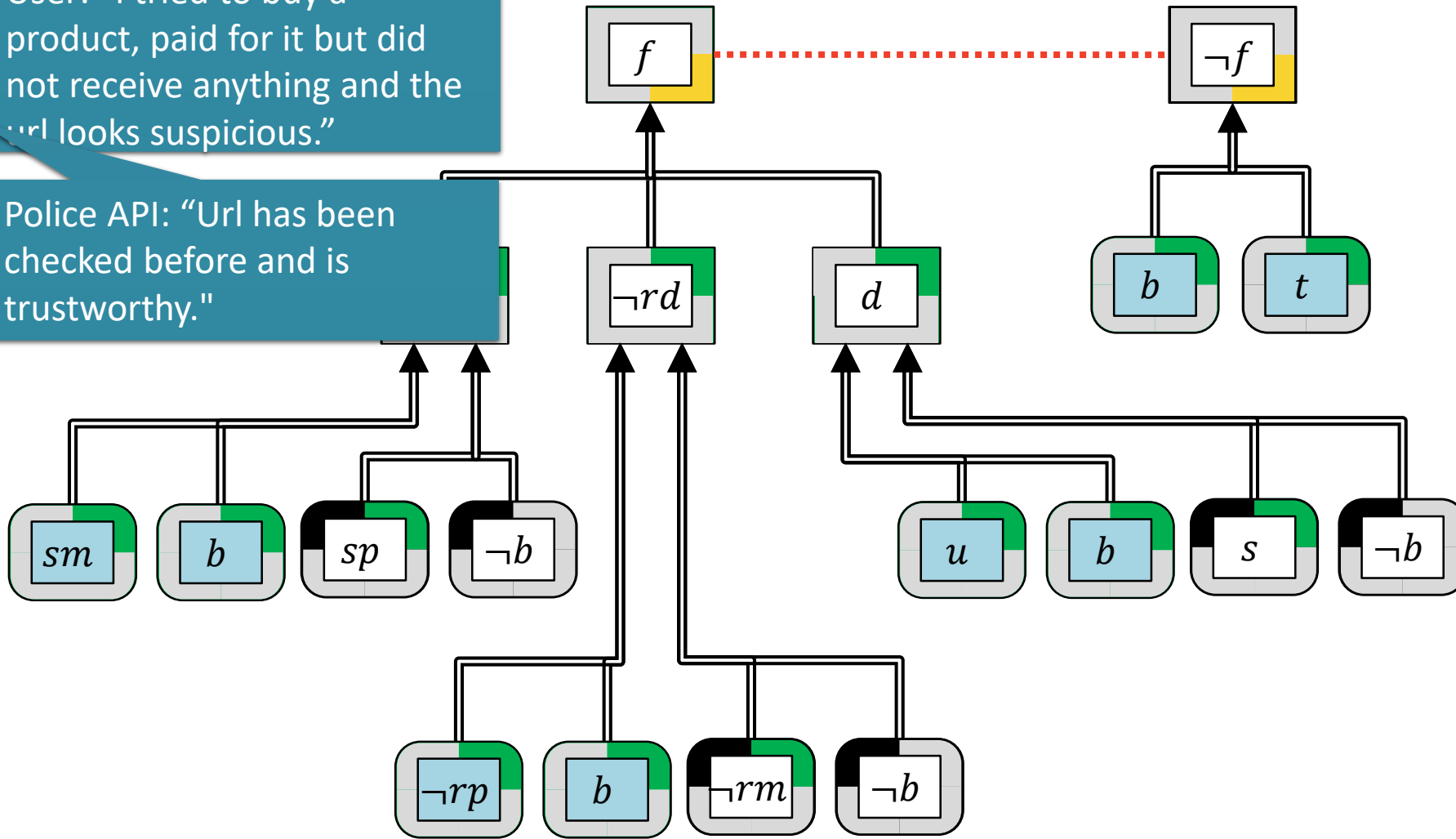

f : fraud
 sd : sent delivery
 rd : received delivery
 d : deception
 b : citizen tried to buy
 t : trusted web shop
 sp : sent product
 rp : received product
 sm : sent money
 rm : received money
 u : suspicious url
 s : screenshot payment

Relevance

A queryable is **relevant** for a claim if adding this queryable as knowledge “contributes to” making the claim stable.*

For a formal definition see:

Odekerken, D., Lehtonen, T., Borg, A., Wallner, J. P., & Järvisalo, M. (2023, August). Argumentative reasoning in ASPIC+ under incomplete information. In *Proceedings of the International Conference on Principles of Knowledge Representation and Reasoning* (Vol. 19, No. 1, pp. 531-541).

User: "I tried to buy a product, paid for it but did not receive anything and the url looks suspicious."

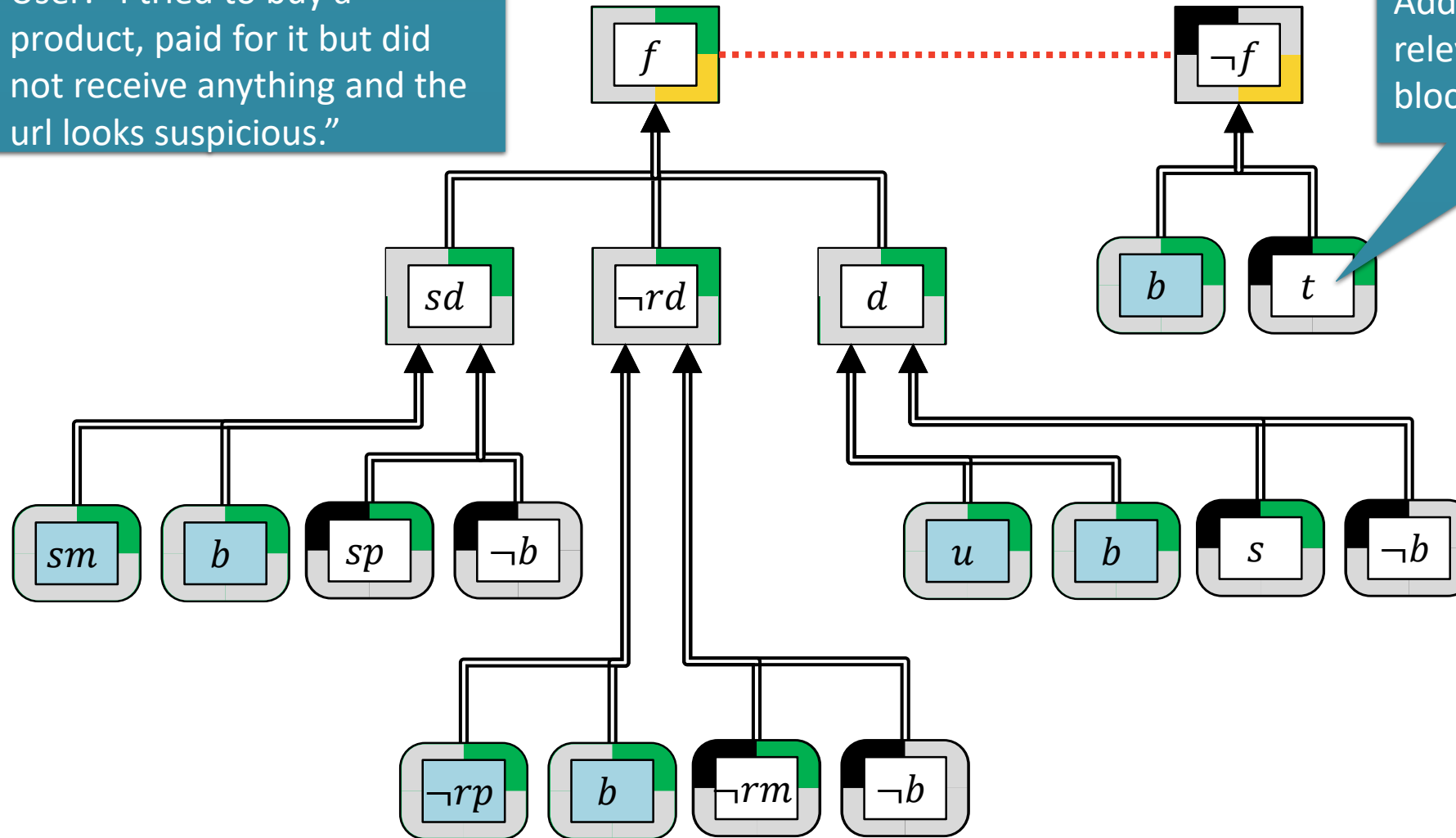

Adding t is blocked-relevant for $\neg f$ and blocked-relevant for f .

- b : citizen tried to buy
- t : trusted web shop
- sp : sent product
- rp : received product
- sm : sent money
- rm : received money
- u : suspicious url
- s : screenshot payment

User: "I tried to buy a product, paid for it but did not receive anything and the url looks suspicious."

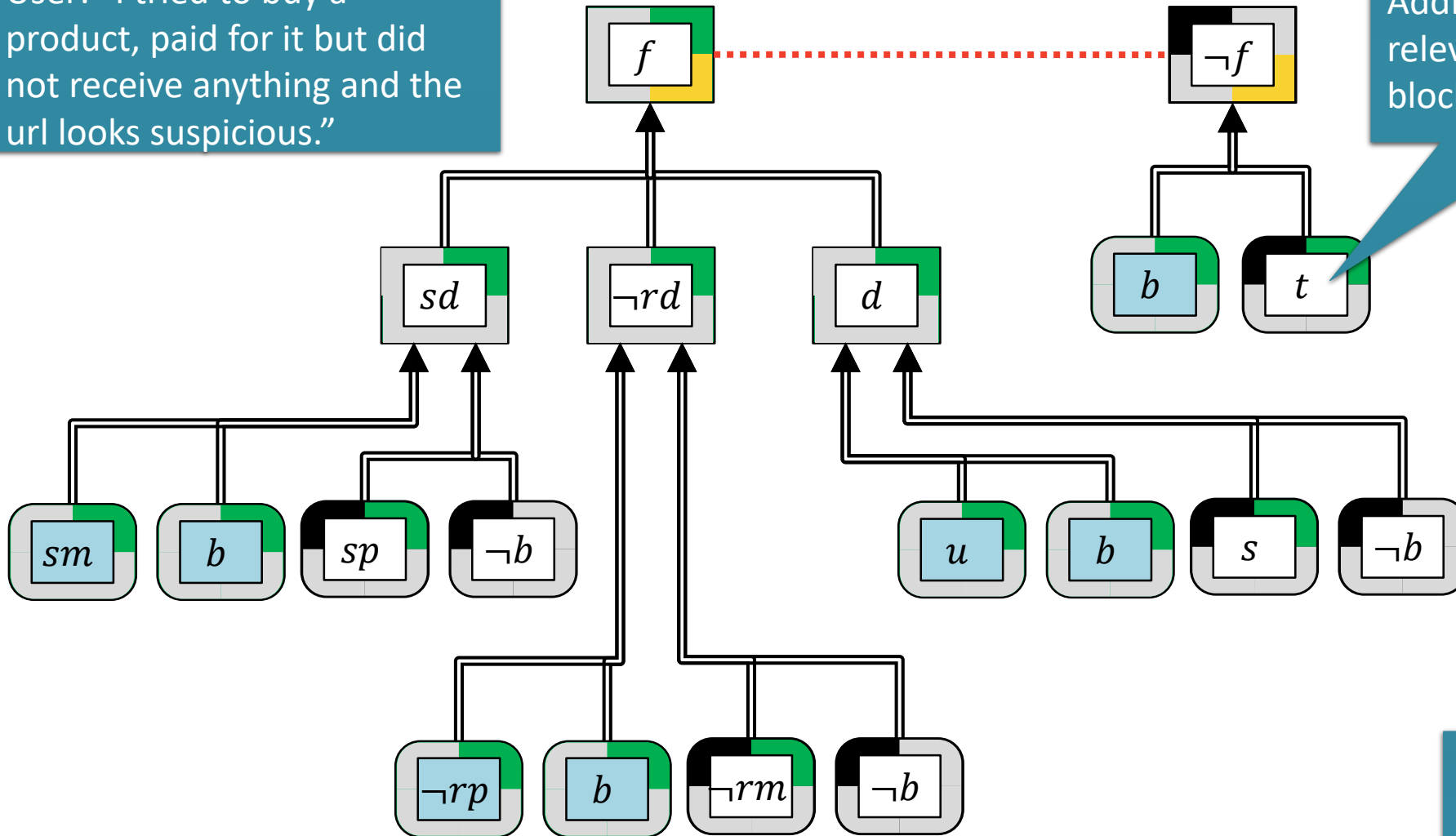

Adding t is blocked-relevant for $\neg f$ and blocked-relevant for f .

- b : citizen tried to buy
- t : trusted web shop
- sp : sent product
- rp : received product
- sm : sent money
- rm : received money
- u : suspicious url
- s : screenshot payment

@Police API:
Can we trust this webshop?

So just compute stability & relevance

Stability

A claim is **stable** if the acceptability status remains the same in all ways in which uncertainty can be resolved.*

*For a formal definition see:

Odekerken, D., Bex, F., Borg, A., & Testerink, B. (2022). Approximating stability for applied argument-based inquiry. *Intelligent Systems with Applications*, 16, 200110.

Just generate all ways in which uncertainty can be resolved and check status

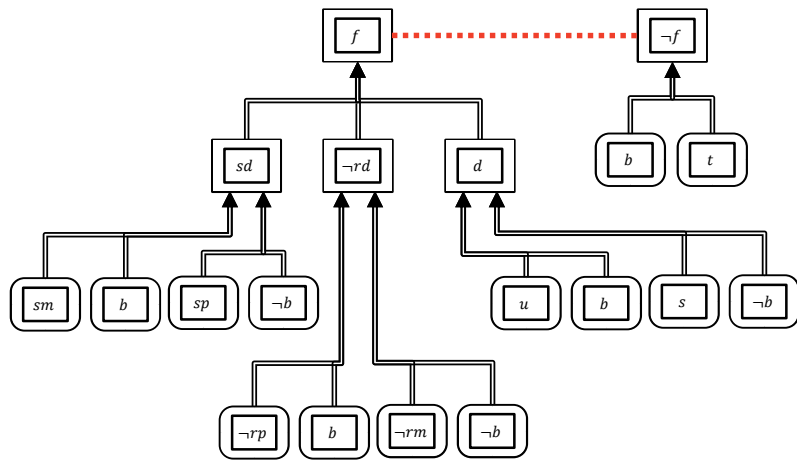

Just generate all ways in which uncertainty can be resolved and check status

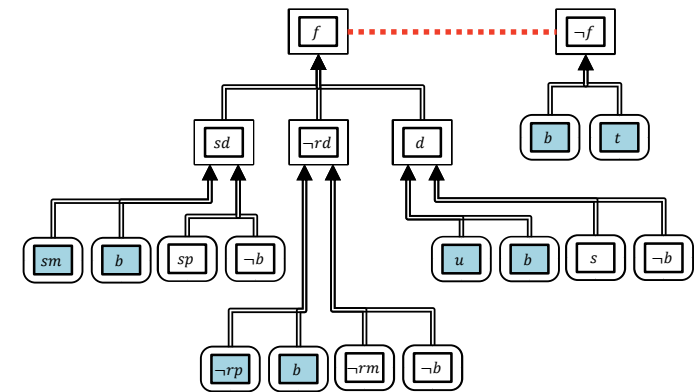
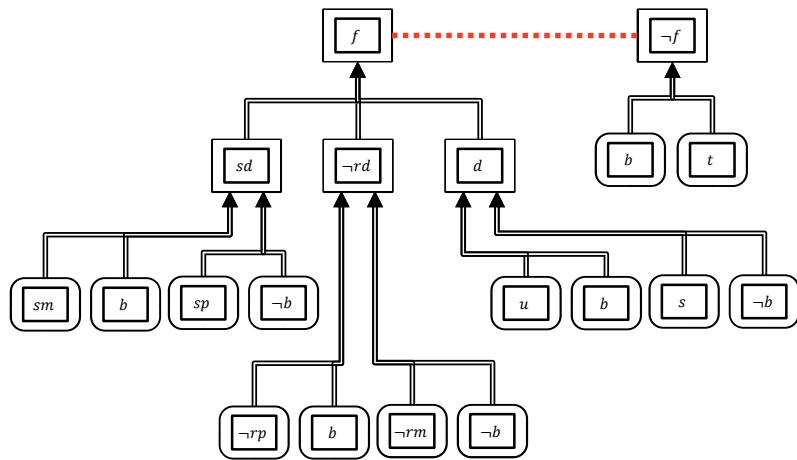

Just generate all ways in which uncertainty can be resolved and check status

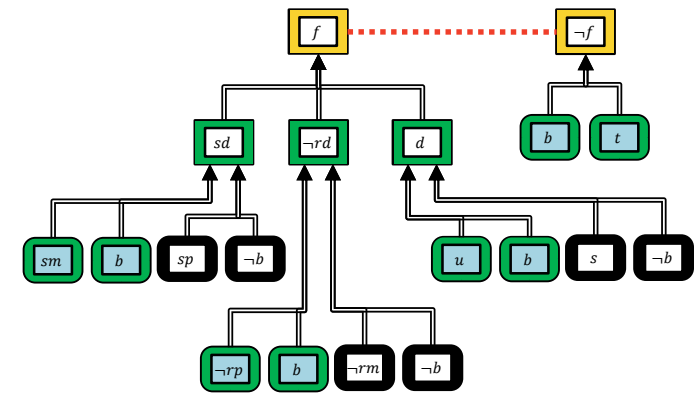
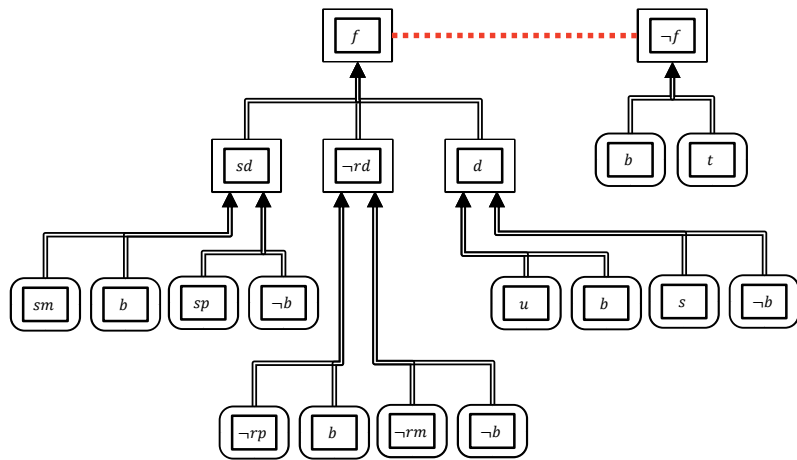

Just generate all ways in which uncertainty can be resolved and check status

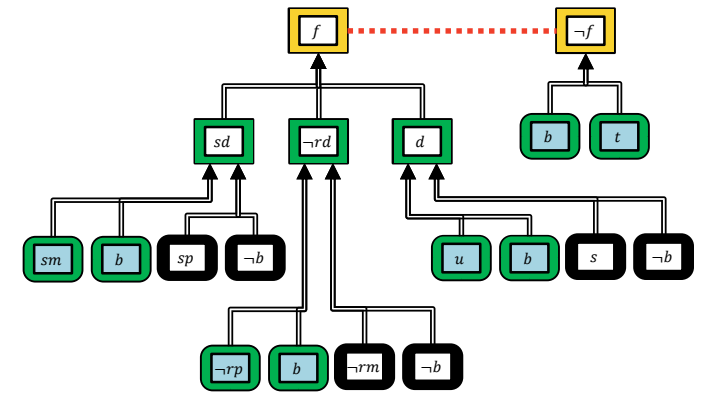
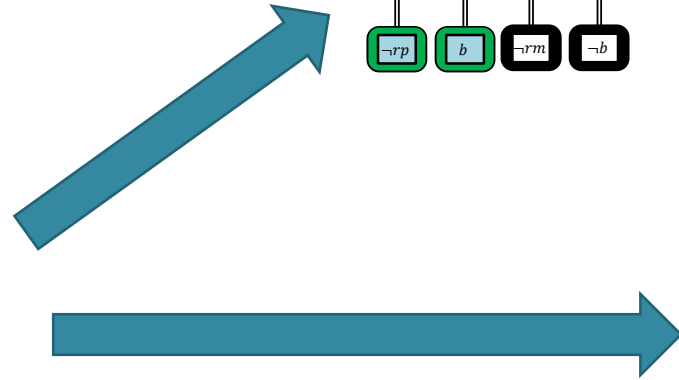
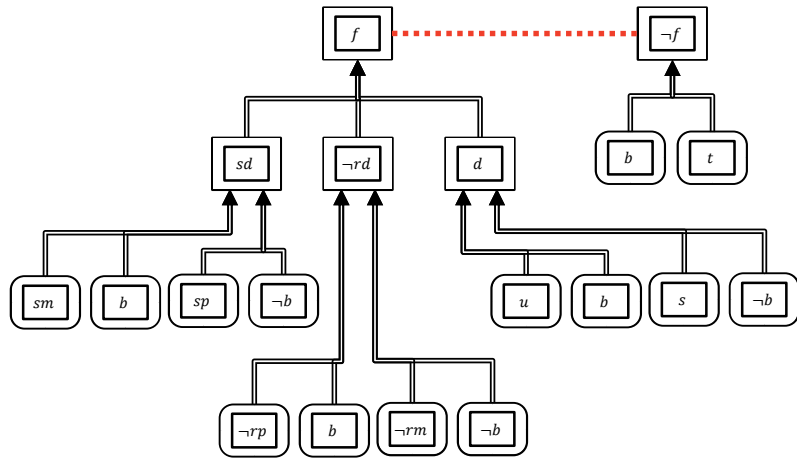
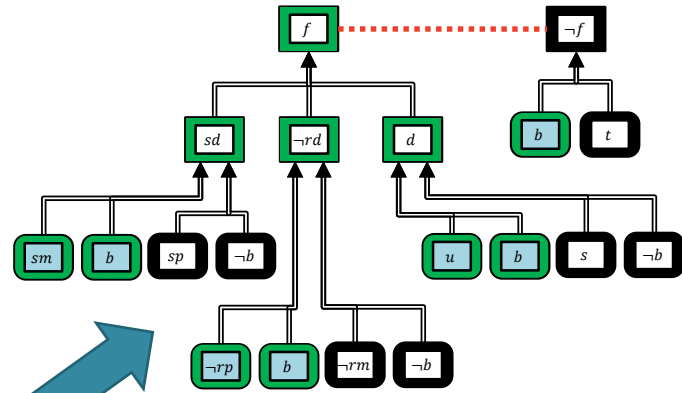

Just generate all ways in which uncertainty can be resolved and check status

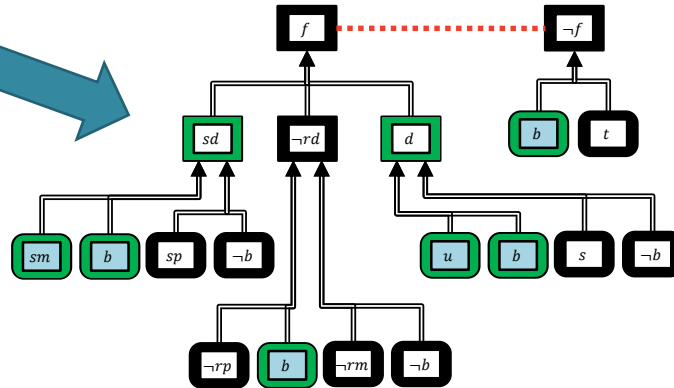
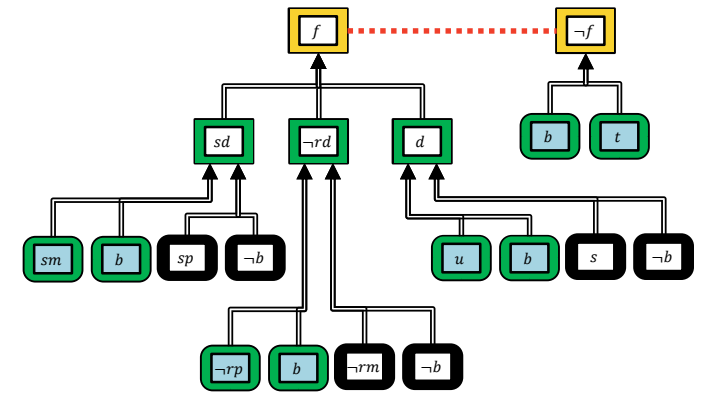
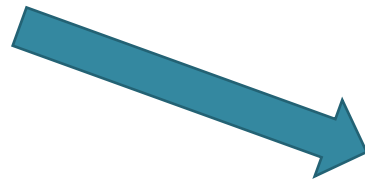
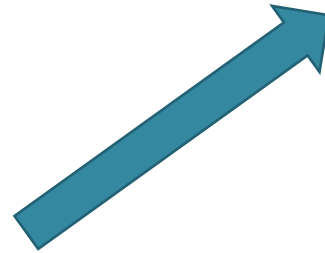
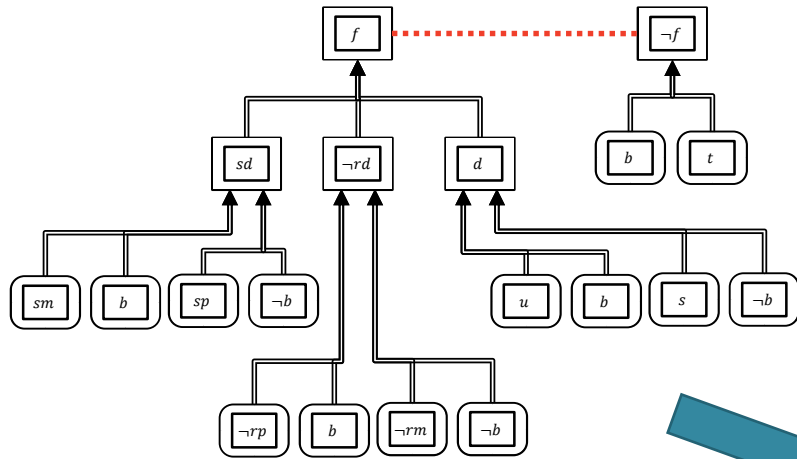
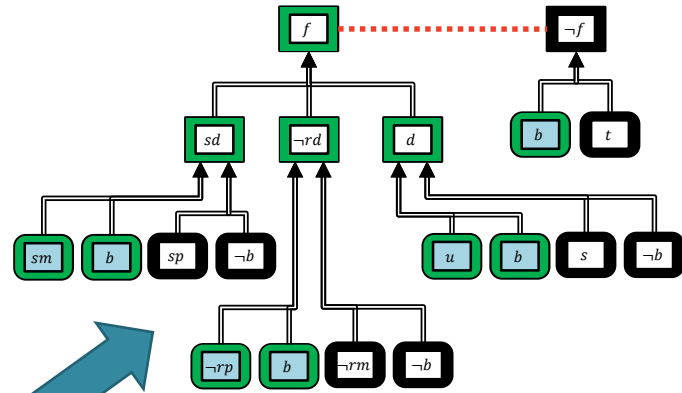

Just generate all ways in which uncertainty can be resolved and check status

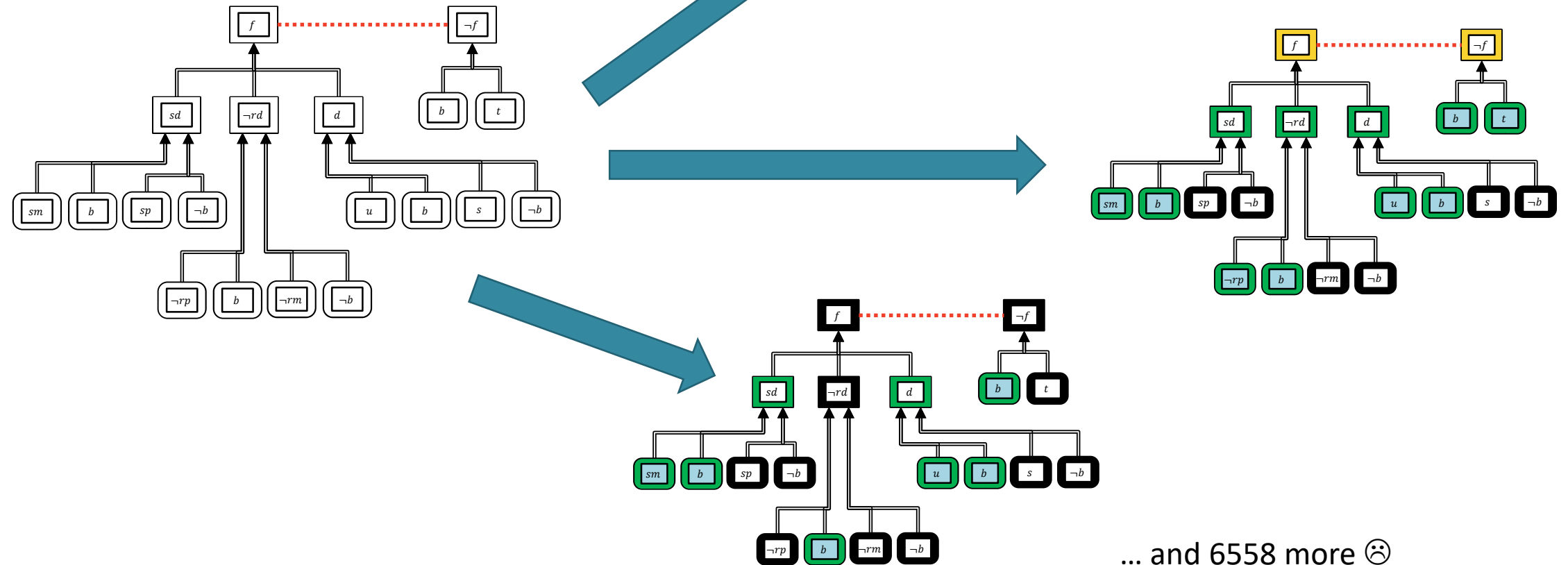

Challenges

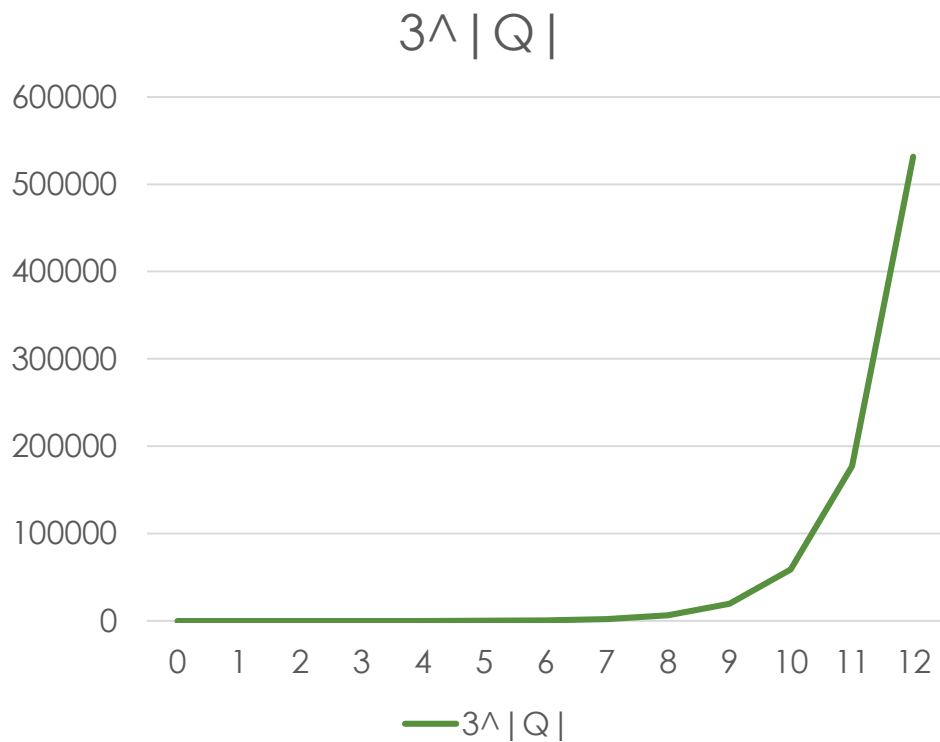

1. Exponential growth of future argumentation theories
2. No fast algorithm (yet) for computing status in 1 argumentation theory

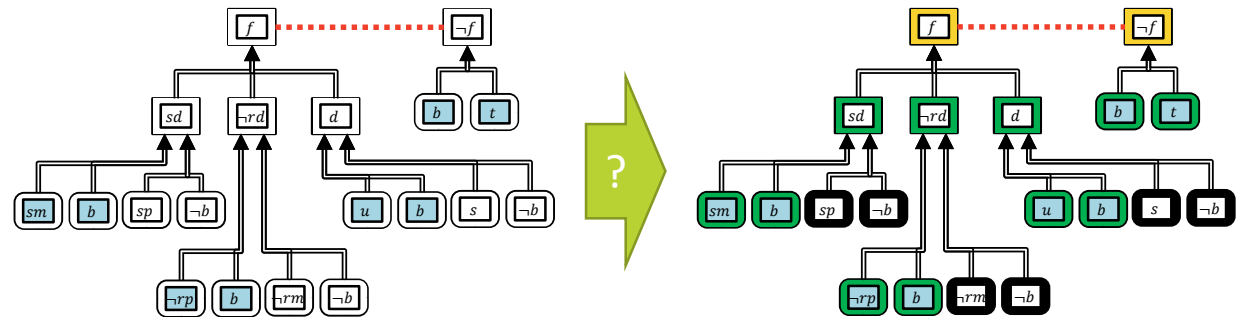

How to realise this technically?

We needed research!

- Complexity analysis of stability (CoNP-c) and relevance problems (Σ_2^P -c) [1,2]
- Labelling-based algorithm for estimating stability [1]
- ASP-based algorithms for computing stability and relevance [2]

[1] Odekerken, D., Bex, F., Borg, A., & Testerink, B. (2022). Approximating stability for applied argument-based inquiry. *Intelligent Systems with Applications*, 16, 200110.

[2] Odekerken, D., Lehtonen, T., Borg, A., Wallner, J. P., & Järvisalo, M. (2023, August). Argumentative reasoning in ASPIC+ under incomplete information. In *Proceedings of the International Conference on Principles of Knowledge Representation and Reasoning* (Vol. 19, No. 1, pp. 531-541).

How to realise this technically?

We needed research!

- Complexity analysis of the stability and relevance problems
- Labelling-based algorithm for estimating stability
- ASP-based algorithms for computing stability and relevance

We needed software developers!

- User interface
- Back-end integration with police systems



8-1328yf 6.400 kg
AIRSERVICE
VW AG

ACHTUNG! WARNING! ATTENTION!
This engine is equipped with a timing chain. It is not recommended to use a timing belt. The timing chain is not designed to be replaced. The timing chain is not designed to be replaced. The timing chain is not designed to be replaced.

Remise/istat Service

Service	Interval
Oil change	10000 km
Filter change	10000 km
Brake pads	10000 km
Brake discs	10000 km
Water pump	10000 km
Timing chain	100000 km

POLITIE

